

User Manual

Data Acquisition Modules/ Distributed IO Modules



COPYRIGHT NOTICE

This manual is a publication of Brainchild Electronics Co., Ltd. and is provided for use by its customers only. The contents of the manual are copyrighted by Brainchild Electronics; reproduction in whole or in part, for use other than in support of Brainchild Electronics equipment, is prohibited without the specific written permission from Brainchild Electronics

SERVICE

If service is required then pack the unit in its original packaging container or, if unavailable, any suitable rigid container. If a substitute container is used, surround the unit with shock absorbing material; damage in shipment is not covered by the warranty. Include a letter with the unit describing the difficulty of usage and request Brainchild for RMA procedure.

Send the equipment to the following address:

Brainchild Electronic. Co. Ltd
6F, 209, Chung yong Road, Nan Kang Dist, Taipei, Taiwan, R.O.C
Tel: +886-2-27861299
Fax: +886-2-27861395
Email: sales@brainchild.com.tw

All returns will be tested to verify customer claims of noncompliance with the product warranty. Improper return packaging, which makes verification impossible, will void the warranty. If noncompliance is verified and is not due to customer abuse or the other exceptions described with product warranty, Brainchild Electronics will, at its option, repair or replace the Product returned to it, freight prepaid, which fail to comply with the foregoing warranty, provided Brainchild is notified of such noncompliance within the one-year warranty period.

ASSISTANCE

This manual is designed to provide the necessary information for trouble-free installation and operation of your new IO Series. However, if you need assistance, please call Brainchild Electronic Co. Ltd. at +886-2-27861299 Ext 613 or visit our web site at [www. Brainchild.com.tw](http://www.Brainchild.com.tw)

MANUAL REVISION

If you contact us in reference to this manual, please include the following document number

Name: User Manual for IO modules
Document: UMIOB, 08, 2007
Revision: 2.0

Warranty Certificate

For New product: This product is warranted against defects in materials and workmanship for a period of 12 months from the date of shipment to Buyer. **For Rectified Products:** Any product that will be replaced will have Warranty for 6 months or up to Original Product Warranty period whichever is greater. The warranty is limited to repair or replacement of the defective unit at the option of the manufacturer. This warranty is void if the product has been altered, misused, dismantled, or otherwise abused.

ALL OTHER WARRANTIES, EXPRESSED OR IMPLIED, ARE EXCLUDED, INCLUDING BUT NOT LIMITED TO THE IMPLIED WARRANTIES OF MERCHANTABILITY AND FITNESS FOR A PARTICULAR PURPOSE.

MAINTENANCE & SERVICE

There are no parts that can be serviced by the user. Service should be performed on a unit substitution basis only. Do not attempt to remove, replace or service any printed circuit board, components or any hardware/software related with display product. If problem within the display product occurs, contact the factory for service information or repair.

Any Mechanical or Electrical Modification to this Unit will void all Warranties

DISCLAIMER

Information contained herein are subject to change without notice. Every precaution has been taken in the preparation of this manual. Nevertheless, Brainchild Electronics assumes no responsibility, express or implied, for errors or omissions or any damages resulting from the use of the information contained in this publication.

All trademarks belong to their respective owners

TABLE OF CONTENTS

1.	AN OVERVIEW OF THE IO SYSTEM	6
1.1	INTRODUCTION	6
1.2	APPLICATION CONFIGURATIONS	6
1.2.1	I/O Expansion	6
1.2.2	Data Acquisition	7
1.3	MODULE SELECTION TABLE	7
2.	IO GENERAL INFORMATION	8
2.1	PHYSICAL DIMENSIONS	8
2.2	GROUNDING/SHIELDING	8
2.3	NETWORK TERMINATION	8
2.4	SETTING THE MODBUS NODE ID	9
2.4.1	Node ID Table	9
2.4.2	DIP Switch Status Register	11
2.5	COMMUNICATIONS SETTINGS	12
2.5.1	Communications Settings with DIP Switch 10 OFF (Default)	12
2.5.2	Communications Settings with DIP Switch 10 ON (Programmed Baud Rate)	12
2.5.3	Communications Settings Registers	12
2.5.4	Modbus Register Types	13
3.	IO MODULES	13
3.1	IO-16DI - DIGITAL INPUTS WITH COUNTERS	13
3.1.1	Description	13
3.1.2	Technical Specification of IO-16DI	14
3.1.3	Status Indicators	14
3.1.4	Wiring	15
3.1.5	Switch Settings	16
3.1.6	IO-16DI Data Registers (MODULE TYPE = 100)	16
3.2	IO-16DO - DIGITAL OUTPUTS	20
3.2.1	Description	20
3.2.2	Technical Specification of IO-16DO	20
3.2.3	Status Indicators	20
3.2.4	Wiring	21
3.2.5	Switch Setting	21
3.2.6	IO-16DO Data Registers (MODULE TYPE = 101)	22
3.3	IO-4RO - RELAY OUTPUTS	23
3.3.1	Description	23
3.3.2	Technical Specification of IO-4RO	23
3.3.3	Status Indicators	23
3.3.4	Wiring	24
3.3.5	Switch Setting	24
3.3.6	IO-4RO Data Registers (MODULE TYPE = 113)	25
3.4	IO-8DIO - DIGITAL INPUTS / OUTPUTS	26
3.4.1	Description	26
3.4.2	Technical Specification of IO-DIO	26
3.4.3	Status Indicators	27
3.4.4	Wiring	27
3.4.5	Switch Settings	28
3.4.6	Jumper Settings	28
3.4.7	IO-8DIO Data Registers (MODULE TYPE = 102)	29
3.5	IO-8AI AND IO-8AIV - ANALOG INPUTS	31
3.5.1	Description	31
3.5.2	Technical Specification of IO-8AI	31
3.5.3	Status Indicators	31
3.5.4	Wiring	32
3.5.5	Switch Settings	33

3.5.6	IO-8AI Data Registers (IO8AI TYPE = 103 / IO-8AIV TYPE = 104)	34
3.6	IO-8AIIS AND IO-8AIVS - ISOLATED ANALOG INPUTS	35
3.6.1	Description	35
3.6.2	Technical Specification of IO-8AIIS and IO-8AIVS	36
3.6.3	Status Indicators	36
3.6.4	Wiring	37
3.6.5	Switch Settings	38
3.6.6	IO-8AIIS Data Registers (8AI TYPE = 107/8AIV TYPE = 108)	38
3.7	IO-8TC - THERMOCOUPLE INPUTS	40
3.7.1	Description	40
3.7.2	Technical Specification of IO-8TC	40
3.7.3	Status Indicators	41
3.7.4	Wiring	41
3.7.5	Switch Settings	42
3.7.6	IO-8TC Data Registers (MODULE TYPE = 105)	42
3.8	IO-8TCS - ISOLATED THERMOCOUPLE INPUTS	43
3.8.1	Description	43
3.8.2	Technical Specification of IO-8TCS	43
3.8.3	Status Indicators	44
3.8.4	Wiring	45
3.8.5	Switch Settings	45
3.8.6	IO-8TCS Data Registers (MODULE TYPE = 106)	46
3.9	IO-6RTD - RTD INPUTS	46
3.9.1	Description	46
3.9.2	Technical Specification of IO-6RTD	47
3.9.3	Status Indicators	47
3.9.4	Wiring	48
3.9.5	Switch Settings	48
3.9.6	IO-6RTD Data Registers (MODULE TYPE = 109)	49
3.10	IO-DAIO – DIGITAL + ANALOG INPUTS AND OUTPUTS	50
3.10.1	Description	50
3.10.2	Technical Specification of IO-DAIO	51
3.10.3	Status Indicators	53
3.10.4	Wiring	53
3.10.5	Switch Settings	54
3.10.6	Jumper Settings	54
3.10.7	IO-DAIO Data Registers (MODULE TYPE = 112)	55
3.11	IO-8AOI - ANALOG OUTPUTS	56
3.11.1	Description	56
3.11.2	Technical Specification of IO-8AOI	57
3.11.3	Status Indicators	57
3.11.4	Wiring	58
3.11.5	Switch Settings	58
3.11.6	IO-8AOI Data Registers (MODULE TYPE = 110)	59
3.12	IO-8AOV - ANALOG OUTPUTS	59
3.12.1	Description	59
3.12.2	Technical Specification of IO-8AOV	60
3.12.3	Status Indicators	60
3.12.4	Wiring	61
3.12.5	Switch Settings	61
3.12.6	IO-8AOV Data Registers (MODULE TYPE = 111)	62
4.	IO STUDIO	63
5.	SPECIFICATIONS	73
5.1	ENVIRONMENTAL	73
5.2	EMC INSTALLATION INSTRUCTIONS	73
5.3	CONFORMITY CERTIFICATE	74
5.4	EMC TEST RESULTS	75

1. AN OVERVIEW OF THE IO SYSTEM

1.1 Introduction

Modular IO system from Brainchild is innovative which provides a simple low cost solution for distributed I/O requirements.

The IO system consists of stand-alone Digital and Analog - Input/Output modules which are connected together on a **RS485** two wire multi-drop network.

The modules communicate using the **MODBUS RTU** protocol. A 32bit ARM CPU is used in the modules to provide high speed data processing and fast communications turn around times. Multiple baud rates are selectable from 2400 to 115200 baud.

All IO modules plug directly onto an industry standard DIN rail. All modules have a minimum isolation of 1000VAC rms between the field and logic.

The modules have been equipped with status led's which are used to indicate the status of the Inputs or outputs. This visual indication assists with fault finding and diagnostics.

1.2 Application Configurations

There are a number of different configurations in which the IO modules may be used in a system. Some are listed as follows:

1.2.1 I/O Expansion.

There are a number of devices such as **PLC's** (Programmable Logic Controllers) and **HMI** (Human machine interface) which have a MODBUS Communications facility available. Many PLC and HMI manufacturers provide Modbus Master and Modbus slave drivers to communicate directly with third party devices using Modbus protocol using different kind of hardware connection. PLC/HMI can be configured as a MODBUS Master. IO modules are attached to the RS485 network and configured as RTU slaves. The address setting is via dip switches on the IO module itself. The PLC/HMI system use IO modules as remote I/O reducing cabling costs and increasing the I/O capability of the control system.

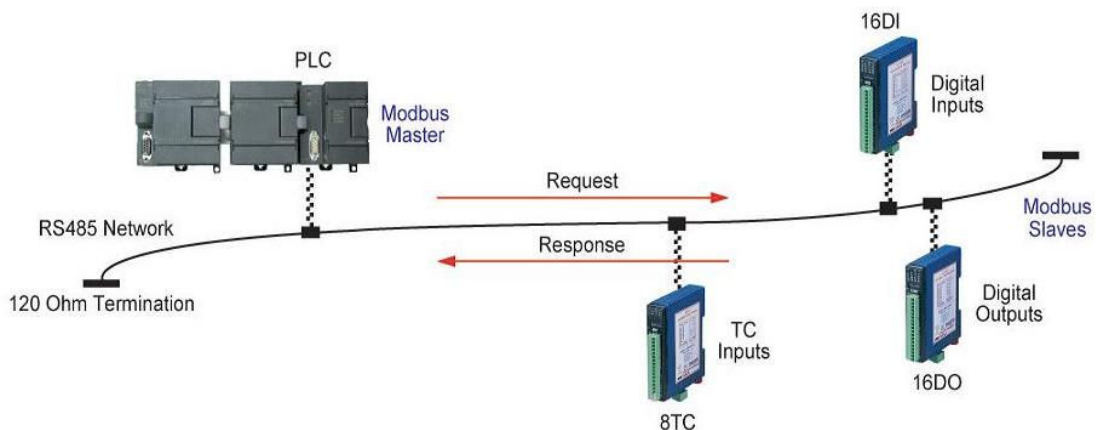

1.2.2 Data Acquisition

Another use of the IO Modules is for Data Acquisition where a **PC** (Personal Computer) is connected to the Network. Many SCADA software packages support the MODBUS Master Protocol and can hence retrieve data from Input Modules or send data to Output Modules. The **serial port** of the PC is connected to an **RS232/RS485 Converter** which in turn is connected to the Network.

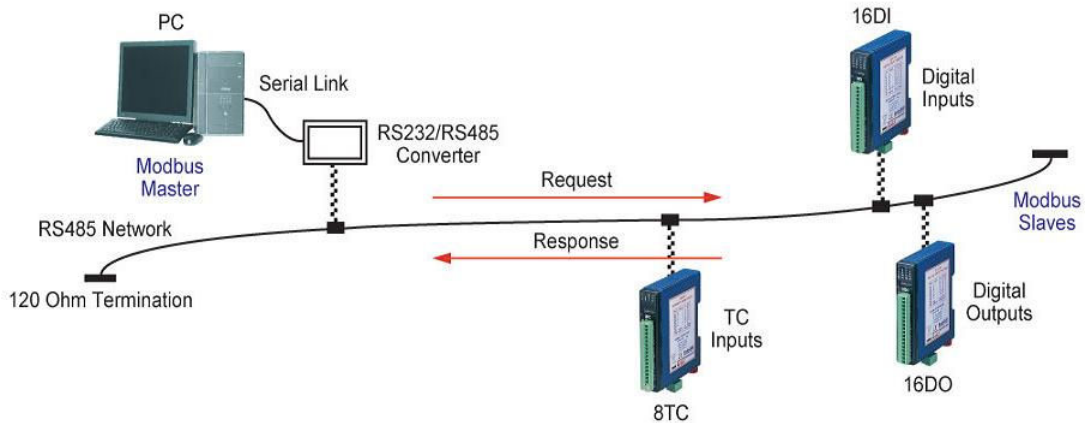

1.3 Module Selection Table

MODEL	MODULE TYPE
I/O MODULES	
IO-16DI	16 DIGITAL INPUT MODULE INCLUDING COUNTERS
IO-16DO	16 DIGITAL OUTPUT MODULE
IO-4RO	4 RELAY OUTPUT MODULE
IO-8DIO	8 DIGITAL INPUT / 8 DIGITAL OUTPUT MODULE
IO-8AII	8 ANALOG INPUT 0 - 20mA / 4 - 20mA
IO-8AIV	8 ANALOG INPUT 0 - 5V / 1 - 5V / 0 - 10V / 2 - 10V
IO-8AIIS	8 ANALOG INPUT 0 - 20mA / 4 - 20mA / ± 20 mA FULLY ISOLATED
IO-8AIVS	8 ANALOG INPUT 0 - 1V / 0 - 10V / ± 1 V / ± 10 V FULLY ISOLATED
IO-8TC	8 THERMOCOUPLE INPUT MODULE INCL. 0 - 50mV & ± 100 mV I/P
IO-8TCS	8 TC INPUT MODULE INCL. 0 - 50mV & ± 100 mV I/P FULLY ISOLATED
IO-6RTD	6 RTD INPUT MODULE - PT100, Ni120, PT1000, Ni1000, Ni1000LG & Ohms
IO-DAIO	2 RTD I/P, 2 ANALOG INPUT 0(4) - 20mA / 0(2) - 10V, 1 ANALOG OUTPUT 0(4) - 20mA / 0(2) - 10V, 4 DIGITAL INPUTS, 2 DIGITAL OUTPUTS
IO-8AOI	8 ANALOG OUTPUT MODULE 0(4) - 20mA
IO-8AOV	8 ANALOG OUTPUT MODULE 0(2) - 10V

2. IO GENERAL INFORMATION

2.1 Physical Dimensions

The IO enclosure is shown below. The module clips directly onto an industry standard DIN rail. Field wiring is on the front of the module via a separate plug in connector. The module power and RS485 communications wiring is on a separate plug in connector on the bottom side of the housing.

Allow at least 25mm on front and below the module to accommodate the wiring. Ensure that enough space is available above and below the module for good ventilation.

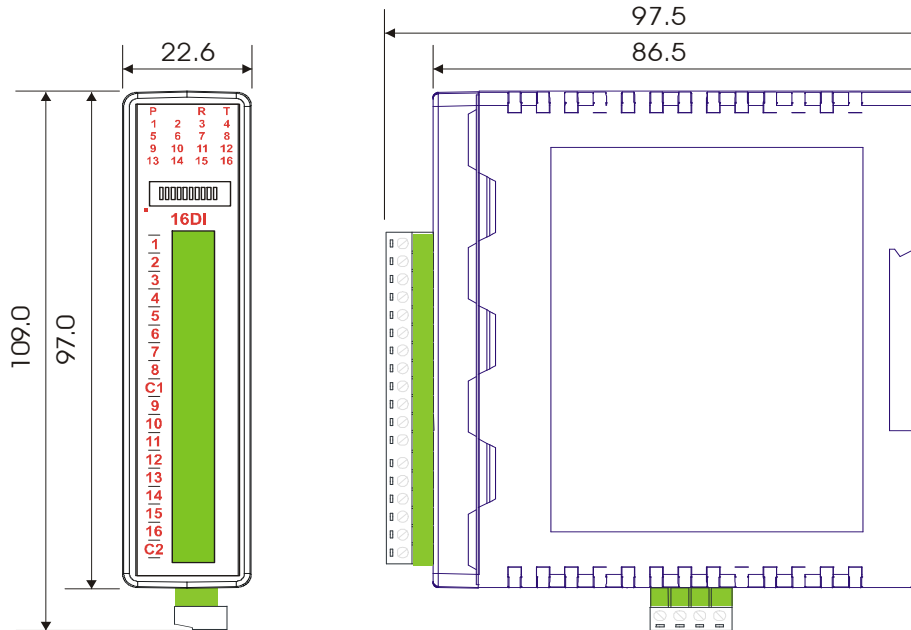

2.2 Grounding/Shielding

In most cases, IO modules will be installed in an enclosure along with other devices which generate electromagnetic radiation. Examples of these devices are relays and contactors, transformers, motor controllers etc. This electromagnetic radiation can induce electrical noise into both power and signal lines, as well as direct radiation into the module causing negative effects on the system. Appropriate grounding, shielding and other protective steps should be taken at the installation stage to prevent these effects. These protective steps include control cabinet grounding, module grounding, cable shield grounding, protective elements for electromagnetic switching devices, correct wiring as well as consideration of cable types and their cross sections.

2.3 Network Termination

Transmission line effects often present a problem on data communication networks. These problems include reflections and signal attenuation.

To eliminate the presence of reflections from the end of the cable, the cable must be terminated at both ends with a resistor across the line equal to its characteristic impedance. Both ends must be terminated since the direction of propagation is bi-directional. In the case of an RS485 twisted pair cable this termination is typically 120 ohms.

2.4 Setting the Modbus Node ID

2.4.1 Node ID Table

The following table assists with the setting up of DIP switches for the required NODE ID.

NODE ID	DIP SWITCH SETTINGS						
	SW1	SW2	SW3	SW4	SW5	SW6	SW7
0	OFF	OFF	OFF	OFF	OFF	OFF	OFF
1	ON	OFF	OFF	OFF	OFF	OFF	OFF
2	OFF	ON	OFF	OFF	OFF	OFF	OFF
3	ON	ON	OFF	OFF	OFF	OFF	OFF
4	OFF	OFF	ON	OFF	OFF	OFF	OFF
5	ON	OFF	ON	OFF	OFF	OFF	OFF
6	OFF	ON	ON	OFF	OFF	OFF	OFF
7	ON	ON	ON	OFF	OFF	OFF	OFF
8	OFF	OFF	OFF	ON	OFF	OFF	OFF
9	ON	OFF	OFF	ON	OFF	OFF	OFF
10	OFF	ON	OFF	ON	OFF	OFF	OFF
11	ON	ON	OFF	ON	OFF	OFF	OFF
12	OFF	OFF	ON	ON	OFF	OFF	OFF
13	ON	OFF	ON	ON	OFF	OFF	OFF
14	OFF	ON	ON	ON	OFF	OFF	OFF
15	ON	ON	ON	ON	OFF	OFF	OFF
16	OFF	OFF	OFF	OFF	ON	OFF	OFF
17	ON	OFF	OFF	OFF	ON	OFF	OFF
18	OFF	ON	OFF	OFF	ON	OFF	OFF
19	ON	ON	OFF	OFF	ON	OFF	OFF
20	OFF	OFF	ON	OFF	ON	OFF	OFF
21	ON	OFF	ON	OFF	ON	OFF	OFF
22	OFF	ON	ON	OFF	ON	OFF	OFF
23	ON	ON	ON	OFF	ON	OFF	OFF
24	OFF	OFF	OFF	ON	ON	OFF	OFF
25	ON	OFF	OFF	ON	ON	OFF	OFF
26	OFF	ON	OFF	ON	ON	OFF	OFF
27	ON	ON	OFF	ON	ON	OFF	OFF
28	OFF	OFF	ON	ON	ON	OFF	OFF
29	ON	OFF	ON	ON	ON	OFF	OFF
30	OFF	ON	ON	ON	ON	OFF	OFF
31	ON	ON	ON	ON	ON	OFF	OFF
32	OFF	OFF	OFF	OFF	OFF	ON	OFF
33	ON	OFF	OFF	OFF	OFF	ON	OFF
34	OFF	ON	OFF	OFF	OFF	ON	OFF
35	ON	ON	OFF	OFF	OFF	ON	OFF
36	OFF	OFF	ON	OFF	OFF	ON	OFF
37	ON	OFF	ON	OFF	OFF	ON	OFF
38	OFF	ON	ON	OFF	OFF	ON	OFF
39	ON	ON	ON	OFF	OFF	ON	OFF
40	OFF	OFF	OFF	ON	OFF	ON	OFF
41	ON	OFF	OFF	ON	OFF	ON	OFF
42	OFF	ON	OFF	ON	OFF	ON	OFF
43	ON	ON	OFF	ON	OFF	ON	OFF
44	OFF	OFF	ON	ON	OFF	ON	OFF

NODE ID	DIP SWITCH SETTINGS						
	SW1	SW2	SW3	SW4	SW5	SW6	SW7
45	ON	OFF	ON	ON	OFF	ON	OFF
46	OFF	ON	ON	ON	OFF	ON	OFF
47	ON	ON	ON	ON	OFF	ON	OFF
48	OFF	OFF	OFF	OFF	ON	ON	OFF
49	ON	OFF	OFF	OFF	ON	ON	OFF
50	OFF	ON	OFF	OFF	ON	ON	OFF
51	ON	ON	OFF	OFF	ON	ON	OFF
52	OFF	OFF	ON	OFF	ON	ON	OFF
53	ON	OFF	ON	OFF	ON	ON	OFF
54	OFF	ON	ON	OFF	ON	ON	OFF
55	ON	ON	ON	OFF	ON	ON	OFF
56	OFF	OFF	OFF	ON	ON	ON	OFF
57	ON	OFF	OFF	ON	ON	ON	OFF
58	OFF	ON	OFF	ON	ON	ON	OFF
59	ON	ON	OFF	ON	ON	ON	OFF
60	OFF	OFF	ON	ON	ON	ON	OFF
61	ON	OFF	ON	ON	ON	ON	OFF
62	OFF	ON	ON	ON	ON	ON	OFF
63	ON	ON	ON	ON	ON	ON	OFF
64	OFF	OFF	OFF	OFF	OFF	OFF	ON
65	ON	OFF	OFF	OFF	OFF	OFF	ON
66	OFF	ON	OFF	OFF	OFF	OFF	ON
67	ON	ON	OFF	OFF	OFF	OFF	ON
68	OFF	OFF	ON	OFF	OFF	OFF	ON
69	ON	OFF	ON	OFF	OFF	OFF	ON
70	OFF	ON	ON	OFF	OFF	OFF	ON
71	ON	ON	ON	OFF	OFF	OFF	ON
72	OFF	OFF	OFF	ON	OFF	OFF	ON
73	ON	OFF	OFF	ON	OFF	OFF	ON
74	OFF	ON	OFF	ON	OFF	OFF	ON
75	ON	ON	OFF	ON	OFF	OFF	ON
76	OFF	OFF	ON	ON	OFF	OFF	ON
77	ON	OFF	ON	ON	OFF	OFF	ON
78	OFF	ON	ON	ON	OFF	OFF	ON
79	ON	ON	ON	ON	OFF	OFF	ON
80	OFF	OFF	OFF	OFF	ON	OFF	ON
81	ON	OFF	OFF	OFF	ON	OFF	ON
82	OFF	ON	OFF	OFF	ON	OFF	ON
83	ON	ON	OFF	OFF	ON	OFF	ON
84	OFF	OFF	ON	OFF	ON	OFF	ON
85	ON	OFF	ON	OFF	ON	OFF	ON
86	OFF	ON	ON	OFF	ON	OFF	ON
87	ON	ON	ON	OFF	ON	OFF	ON
88	OFF	OFF	OFF	ON	ON	OFF	ON
89	ON	OFF	OFF	ON	ON	OFF	ON
90	OFF	ON	OFF	ON	ON	OFF	ON
91	ON	ON	OFF	ON	ON	OFF	ON
92	OFF	OFF	ON	ON	ON	OFF	ON
93	ON	OFF	ON	ON	ON	OFF	ON
94	OFF	ON	ON	ON	ON	OFF	ON
95	ON	ON	ON	ON	ON	OFF	ON
96	OFF	OFF	OFF	OFF	OFF	ON	ON
97	ON	OFF	OFF	OFF	OFF	ON	ON

NODE ID	DIP SWITCH SETTINGS						
	SW1	SW2	SW3	SW4	SW5	SW6	SW7
98	OFF	ON	OFF	OFF	OFF	ON	ON
99	ON	ON	OFF	OFF	OFF	ON	ON
100	OFF	OFF	ON	OFF	OFF	ON	ON
101	ON	OFF	ON	OFF	OFF	ON	ON
102	OFF	ON	ON	OFF	OFF	ON	ON
103	ON	ON	ON	OFF	OFF	ON	ON
104	OFF	OFF	OFF	ON	OFF	ON	ON
105	ON	OFF	OFF	ON	OFF	ON	ON
106	OFF	ON	OFF	ON	OFF	ON	ON
107	ON	ON	OFF	ON	OFF	ON	ON
108	OFF	OFF	ON	ON	OFF	ON	ON
109	ON	OFF	ON	ON	OFF	ON	ON
110	OFF	ON	ON	ON	OFF	ON	ON
111	ON	ON	ON	ON	OFF	ON	ON
112	OFF	OFF	OFF	OFF	ON	ON	ON
113	ON	OFF	OFF	OFF	ON	ON	ON
114	OFF	ON	OFF	OFF	ON	ON	ON
115	ON	ON	OFF	OFF	ON	ON	ON
116	OFF	OFF	ON	OFF	ON	ON	ON
117	ON	OFF	ON	OFF	ON	ON	ON
118	OFF	ON	ON	OFF	ON	ON	ON
119	ON	ON	ON	OFF	ON	ON	ON
120	OFF	OFF	OFF	ON	ON	ON	ON
121	ON	OFF	OFF	ON	ON	ON	ON
122	OFF	ON	OFF	ON	ON	ON	ON
123	ON	ON	OFF	ON	ON	ON	ON
124	OFF	OFF	ON	ON	ON	ON	ON
125	ON	OFF	ON	ON	ON	ON	ON
126	OFF	ON	ON	ON	ON	ON	ON
127	ON	ON	ON	ON	ON	ON	ON

All modules will respond to a default Node ID of 254.

2.4.2 DIP Switch Status Register.

Each module uses register 30100 to store the status of the DIP switches.

DIP SWITCH REGISTER													ADDRESS					
MSB	15	14	13	12	11	10	9	8	7	6	5	4	3	2	1	0	LSB	
	32768	16384	8192	4096	2048	1024	512	256	128	64	32	16	8	4	2	1		30100

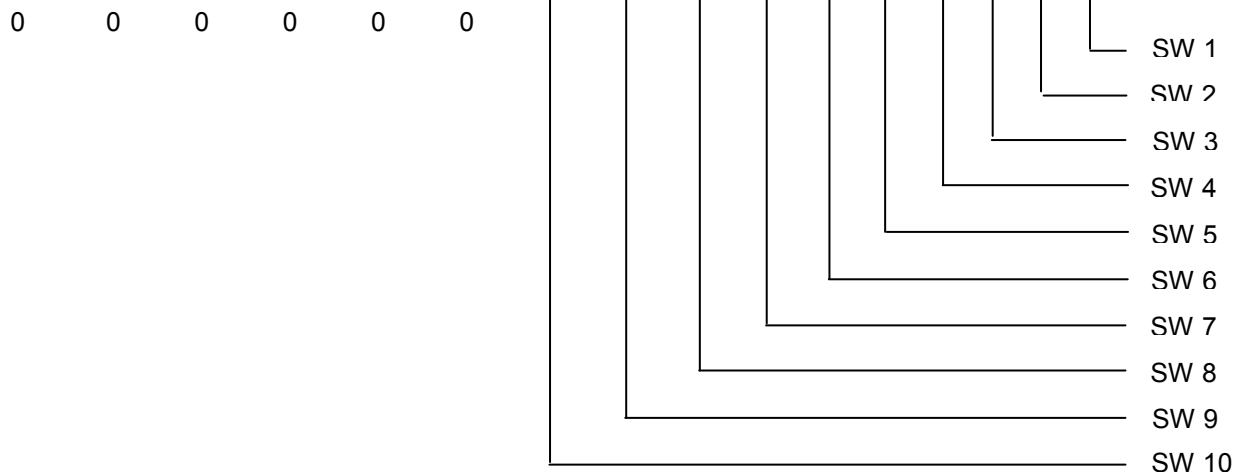

2.5 Communications Settings

The data in the modules is stored in 16 bit registers. These registers are accessed over the network using the MODBUS RTU communication protocol.

2.5.1 Communications Settings with DIP Switch 10 OFF (Default)

BAUD RATE	9600
DATA BITS	8
PARITY	NONE
STOP BITS	1

2.5.2 Communications Settings with DIP Switch 10 ON (Programmed Baud Rate)

BAUD RATE	2400, 4800, 9600, 19200, 38400, 57600, 115200
DATA BITS	8
PARITY	None, Even, Odd
STOP BITS	1, 2

Note: These settings are done from IO Studio PC software or Modbus Master device.
For ex: If you are planning to use HMI (Brainchild) as Master device, then it is possible to set above parameters writing a small application program in HMI. During this mode, DIP switch10 should be OFF such that, Master device can communicate with IO module on default communication settings.

2.5.3 Communications Settings Registers

40121	Baud Rate	2400	11520	R/W	2400, 4800, 9600, 19200, 38400,57600,11520
40122	Parity	0	2	R/W	0 = none, 1 = even, 2 = odd
40123	Stop Bits	1	2	R/W	1 = 1 stop bit, 2 = 2 stop bits
40124	Reply Delay	0	65535	R/W	(x10ms)

2.5.3.1 Baud Rate Register (40121)

The baud rate value is programmed directly into the baud rate register. The only exception is the 115200 baud rate where the value 11520 is used.

2.5.3.2 Parity Register (40122)

The parity can be set to none by writing a 0 to the parity register, set to even by writing a 1 to the parity Register or set to odd by writing a 2 to the parity register.

2.5.3.3 Stop Bits Register (40123)

The number of stop bits can be set to 1 by writing a 1 to the stop bits register or set to 2 by writing a 2 to the stop bits Register.

2.5.3.4 Reply Delay Register (40124)

The reply delay is a time delay between the Modbus message received to the reply being sent. In some applications where a modem or radio is used in the RS485 network, it may be necessary to add a reply delay due to turn around delays in the equipment.

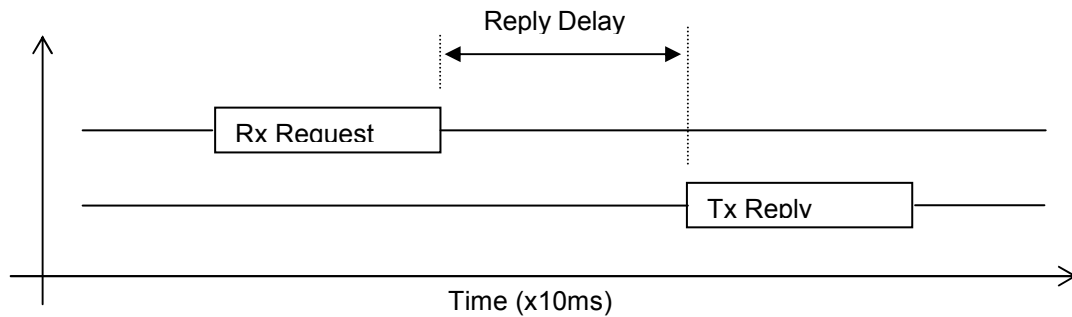

2.5.4 Modbus Register Types

There are 4 types of variables which can be accessed from the module. Each module has one or more of these data variables.

Type	Start Address	Variable	Access
1	00001	Digital Outputs	Read & Write
2	10001	Digital Inputs	Read Only
3	30001	Input registers (Analog)	Read Only
4	40001	Output registers (Analog) (Holding type)	Read & Write

Note: The Modbus message length must be limited to 100 consecutive read or write registers. If more registers are required then a new poll group must be added for the next xxx registers.

3. IO MODULES

3.1 IO-16DI - DIGITAL INPUTS WITH COUNTERS

3.1.1 Description

The IO-16DI module is a 16 channel digital input module. The inputs are isolated from the logic by bi-directional opto-couplers. The inputs are divided into 2 isolated groups of 8 inputs each. This allows for many configurations in which the input module may be used. One such configuration could be where one group is connected as common positive and the second group connected as common negative.

The counters operate in three modes.

In **mode 0**: All the counters are disabled.

In **mode 1**: The counters are 32 bit counters allowing a count value from 0 to 4294967295. The count value can be cleared by writing a zero to the associated registers or preset to any other value using the same method.

In **mode 2**: The inputs are connected as up/down counters. Input 1 will increment counter 1 while input 2 decrements counter1. In the same way, inputs 3&4 operate counter 2, inputs 5&6 operate counter 3 and inputs 7&8 operate counter 4 etc..

Note: The count values are not battery backed-up and will be lost if power is turned off.

The format of the registers allows the status of the inputs to be read as either single bits or all at once as a single register on the Modbus network.

3.1.2 Technical Specification of IO-16DI

Power Supply	Logic Supply Voltage	12 -24 Vdc
	Logic Supply Current	30mA @ 12V / 17mA @ 24V
Digital Inputs	Input Points	16
	Input Voltage Range	12 - 24 Vdc
	Input Current per input	5mA @ 12Vdc / 11mA @ 24Vdc
	Isolation	1500Vrms between field and logic
Counters	Inputs	1 to 16
	Resolution	32 Bits
	Frequency	1KHz (max)
	Pulse Width	500us (min)
Temperature	Operating Temperature.	-10°C to + 50°C
	Storage Temperature	-40°C to + 85°C
Connectors	Logic Power and Comms.	4 Pin Connector on bottom side of unit
	Inputs	18 Way screw connector on front

Note: Inputs 1 to 16 are used as both digital inputs and counter inputs.

3.1.3 Status Indicators

- Power:** Flashes to indicate the CPU is running.
- RS485 Rx:** Flashes to indicate the unit has received a valid Modbus message.
- RS485 Tx:** Flashes to indicate the unit has sent a Modbus message.
- Input Status:** "OFF" when the input is off.
"ON" when the input is on.

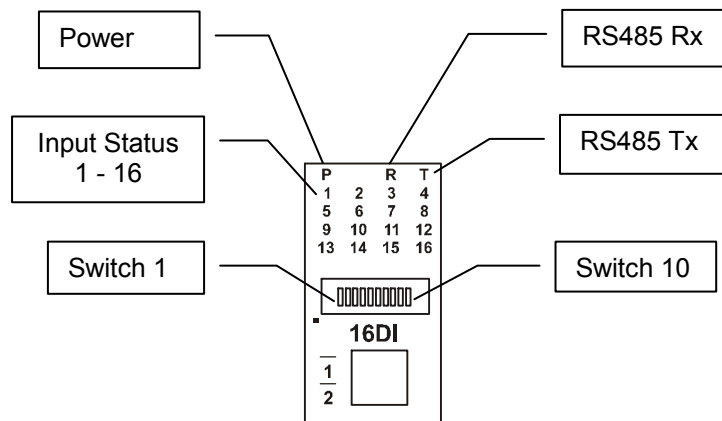

3.1.4 Wiring

The following diagram shows how the digital inputs are connected to potential free switches. The common can be connected to positive or negative as indicated.

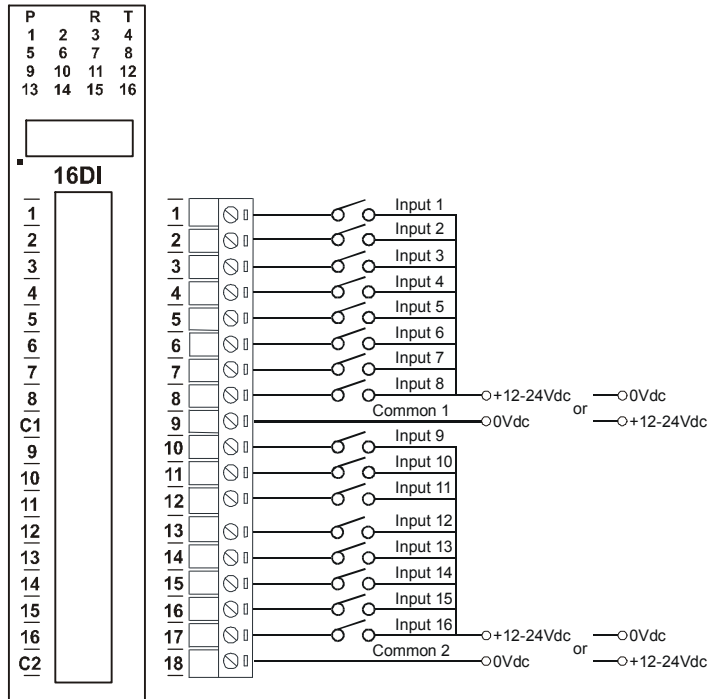

The following diagram shows how the digital inputs are connected a NPN transistor or a PNP transistor.

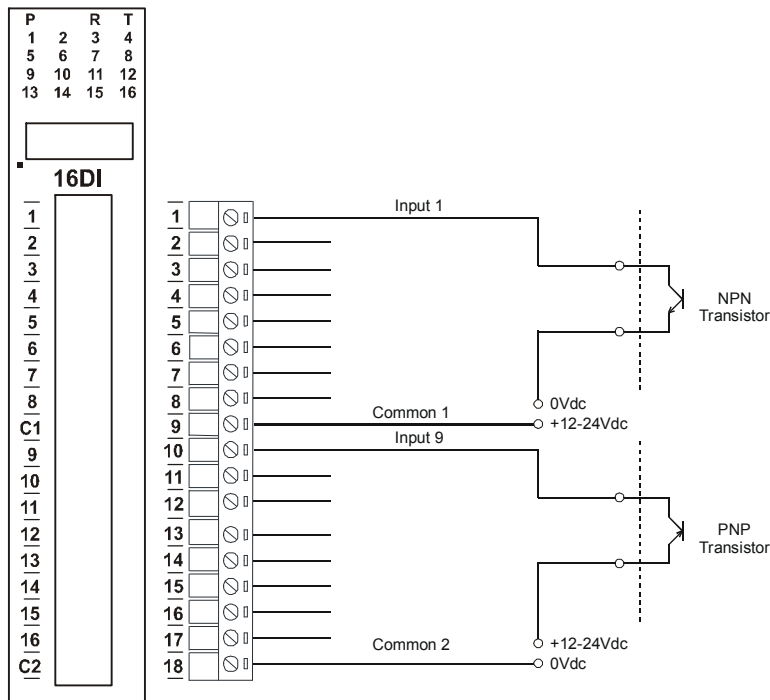

The following diagram shows the wiring for the power and RS485 communications.

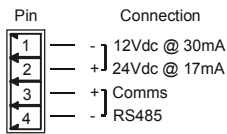

Note: If power/communication connections are reversed, module may become faulty.

3.1.5 Switch Settings

SWITCH	FUNCTION	DESCRIPTION
1	NODE ID +1	Node ID's from 0 to 127 are set up using switches 1 to 7
2	NODE ID +2	"
3	NODE ID +4	"
4	NODE ID +8	"
5	NODE ID +16	"
6	NODE ID +32	"
7	NODE ID +64	"
8	INVERT	When switched ON the status of the inputs is inverted in the Modbus status register (30002).
9	-	Not Used.
10	BAUD RATE	Selects 9600 (off) or Programmed Baud Rate (on)

3.1.6 IO-16DI Data Registers (MODULE TYPE = 100)

Modbus Address	Register Name	Low Limit	High Limit	Access	Description
10001	Digital Input 1	0	1	R	Status of Digital Inputs.
10002	Digital Input 2	0	1	R	"
10003	Digital Input 3	0	1	R	"
10004	Digital Input 4	0	1	R	"
10005	Digital Input 5	0	1	R	"
10006	Digital Input 6	0	1	R	"
10007	Digital Input 7	0	1	R	"
10008	Digital Input 8	0	1	R	"
10009	Digital Input 9	0	1	R	"
10010	Digital Input 10	0	1	R	"
10011	Digital Input 11	0	1	R	"
10012	Digital Input 12	0	1	R	"
10013	Digital Input 13	0	1	R	"
10014	Digital Input 14	0	1	R	"
10015	Digital Input 15	0	1	R	"
10016	Digital Input 16	0	1	R	"

Modbus Address	Register Name	Low Limit	High Limit	Access	Description
30001	S/W Version / Module Type	N/A	N/A	R	High Byte = Software Version Low Byte = 100
30002	Digital Inputs	N/A	N/A	R	Digital Inputs in 16 bits. 16 - 1.
40003	Counter 1 MSB	0	65535	R/W	Counter MSB and LSB combine to give a 32 bit Counter with range 0 to 4294967295.
40004	Counter 1 LSB	0	65535	R/W	
40005	Counter 2 MSB	0	65535	R/W	"
40006	Counter 2 LSB	0	65535	R/W	"
40007	Counter 3 MSB	0	65535	R/W	"
40008	Counter 3 LSB	0	65535	R/W	"
40009	Counter 4 LSB	0	65535	R/W	"
40010	Counter 4 LSB	0	65535	R/W	"
40011	Counter 5 MSB	0	65535	R/W	"
40012	Counter 5 LSB	0	65535	R/W	"
40013	Counter 6 MSB	0	65535	R/W	"
40014	Counter 6 LSB	0	65535	R/W	"
40015	Counter 7 MSB	0	65535	R/W	"
40016	Counter 7 LSB	0	65535	R/W	"
40017	Counter 8 MSB	0	65535	R/W	"
40018	Counter 8 LSB	0	65535	R/W	"
40019	Counter 9 MSB	0	65535	R/W	"
40020	Counter 9 LSB	0	65535	R/W	"
40021	Counter 10MSB	0	65535	R/W	"
40022	Counter 10LSB	0	65535	R/W	"
40023	Counter 11MSB	0	65535	R/W	"
40024	Counter 11LSB	0	65535	R/W	Counter MSB and LSB combine to give a 32 bit Counter with range 0 to 4294967295.
40025	Counter 12MSB	0	65535	R/W	Counter with range 0 to 4294967295.
40026	Counter 12LSB	0	65535	R/W	"
40027	Counter 13MSB	0	65535	R/W	"
40028	Counter 13LSB	0	65535	R/W	"
40029	Counter 14MSB	0	65535	R/W	"
40030	Counter 14LSB	0	65535	R/W	"
40031	Counter 15MSB	0	65535	R/W	"
40032	Counter 15LSB	0	65535	R/W	"
40033	Counter 16MSB	0	65535	R/W	"
40034	Counter 16LSB	0	65535	R/W	"
40035	Counter Capture	0	65535	R/W	Bit1 = 1 to Capture Counter1, Bit2 = 1 to Capture Counter2, etc.
40036	CCounter 1 MSB	0	65535	R/W	Capture Counter Registers. MSB and LSB combine to give a 32 bit Value.
40037	CCounter 1 LSB	0	65535	R/W	
40038	CCounter 2 MSB	0	65535	R/W	Counter with range 0 to 4294967295.
40039	CCounter 2 LSB	0	65535	R/W	"
40040	CCounter 3 MSB	0	65535	R/W	"
40041	CCounter 3 LSB	0	65535	R/W	"
40042	CCounter 4 LSB	0	65535	R/W	"
40043	CCounter 4 LSB	0	65535	R/W	"

Modbus Address	Register Name	Low Limit	High Limit	Access	Description
40044	CCounter 5 MSB	0	65535	R/W	"
40045	CCounter 5 LSB	0	65535	R/W	"
40046	CCounter 6 MSB	0	65535	R/W	"
40047	CCounter 6 LSB	0	65535	R/W	"
40048	CCounter 7 MSB	0	65535	R/W	"
40049	CCounter 7 LSB	0	65535	R/W	"
40050	CCounter 8 MSB	0	65535	R/W	"
40051	CCounter 8 LSB	0	65535	R/W	"
40052	CCounter 9 MSB	0	65535	R/W	"
40053	CCounter 9 LSB	0	65535	R/W	"
40054	CCounter 10MSB	0	65535	R/W	"
40055	CCounter 10LSB	0	65535	R/W	"
40056	CCounter 11MSB	0	65535	R/W	"
40057	CCounter 11LSB	0	65535	R/W	"
40058	CCounter 12MSB	0	65535	R/W	"
40059	CCounter 12LSB	0	65535	R/W	"
40060	CCounter 13MSB	0	65535	R/W	"
40061	CCounter 13LSB	0	65535	R/W	"
40062	CCounter 14MSB	0	65535	R/W	"
40063	CCounter 14LSB	0	65535	R/W	"
40064	CCounter 15MSB	0	65535	R/W	"
40065	CCounter 15LSB	0	65535	R/W	"
40066	CCounter 16MSB	0	65535	R/W	"
40067	CCounter 16LSB	0	65535	R/W	"
30100	DIP Switch	0	65535	R	Status of DIP Switch on Front Panel
40101	Counter Mode	0	2	R/W	0=Disable, 1=Up Counting, 2=Up/Down Count
40102	Input Filter	0	65535	R/W	0 = Disable, >0 = Enable. (x10ms)
40103	Capture Zero	0	65535	R/W	0 = Disabled, bit1 = auto zero counter 1.
40121	Baud Rate	2400	11520	R/W	2400, 4800, 9600, 19200, 38400,57600,115200
40122	Parity	0	2	R/W	0 = none, 1 = even, 2 = odd
40123	Stop Bits	1	2	R/W	1 = 1 stop bit, 2 = 2 stop bits
40124	Reply Delay	0	65535	R/W	0 = Disable, >0 = Enable. (x10ms)

3.1.6.1 Digital Input Register.

The digital inputs can be read in a single register as follows:

IO-6DI DIGITAL INPUTS															ADDRESS			
MSB	15	14	13	12	11	10	9	8	7	6	5	4	3	2		1	0	LSB
	32768	16384	8192	4096	2048	1024	512	256	128	64	32	16	8	4	2	1		30002
	16	15	14	13	12	11	10	9	8	7	6	5	4	3	2	1		

Digital Input Number

3.1.6.2 Counter Registers.

The counters are stored a two 16 bit registers. The first register is the High Register and the second register is the Low Register. To get the actual 32 bit count value the registers must be combined as follows:

Counter High Value = Register 40003.

Counter Low Value = Register 40004.

Counter Value = (Counter High Value X 65535) + Counter Low Value.

3.1.6.3 Counter Capture.

To capture a counter a 1 must be written to the corresponding bit position in the Counter Capture Register 40035. For example:

1. Writing 1 to Register 40035 results in Counter 1 value being captured to Counter Capture 1.
2. Writing 2 to Register 40035 results in Counter 2 value being captured to Counter Capture 2.
3. Writing 3 to Register 40035 results in Counter 1 value being captured to Counter Capture 1 and Counter 2 value being captured to Counter Capture 2.

Once the module has captured the counters the Counter Capture Register 40035 is cleared to zero. It is possible to read this register to get confirmation that the capture is complete before reading the captured counter values.

3.1.6.4 Counter Auto Zero.

The counter being captured can be auto zeroed. The purpose of this function is to let the module zero the counter so that no counts get lost due to delays from communication latency, etc.

To ensure that a counter is auto zeroed, a 1 must be written to the corresponding bit position in the Capture Zero Register 40103. For example:

Writing 1 to Register 40103 results in Counter 1 value being zeroed when the Counter Capture bit is 1, the value in the Capture Zero Register 40103 is permanently stored in memory and only has to be configured once.

3.2 IO-16DO - DIGITAL OUTPUTS

3.2.1 Description

This module has 16 open collector (NPN) digital outputs. The outputs may be used to drive lamps or external relays when more drive capability is required. The outputs are isolated from the logic and they share a common negative terminal. When switch 9 is off, the module is configured as a slave module for the Modbus master device such as a PC / PLC / HMI.

When used as a slave module, the outputs are written to by the Modbus master device such as a PC/PLC/HMI. Each output can be individually switched on or off, or all outputs can be set up at the same time by writing a single number to the output register which represents the status of all outputs.

An output watchdog timer can be configured to switch off all the outputs if there has been no communications with the module for up to 255 seconds. A value of 0 seconds will disable this timer and the outputs will remain in the last programmed state.

3.2.2 Technical Specification of IO-16DO

Power Supply	Logic Supply Voltage	12 -24 Vdc
	Logic Supply Current	23mA @ 12V / 14mA @ 24V
	Field Supply Voltage	12 -24 Vdc
	Field Supply Current	6mA @ 12V / 6mA @ 24V
Digital Outputs	Output Points	16
	Maximum Voltage	36 Vdc
	Maximum Current	100 mA per output
	Vceon	1.1V Max
	Isolation	1500Vrms between field and logic
Temperature	Operating Temperature.	-10°C to + 50°C
	Storage Temperature	-40°C to + 85°C
Connectors	Logic Power and Comms.	4 Pin Connector on underside of unit
	Outputs	18 Way screw connector on front

3.2.3 Status Indicators

- Power:** Flashes to indicate the CPU is running.
RS485 Rx: Flashes to indicate the unit has received a valid Modbus message.
RS485 Tx: Flashes to indicate the unit has sent a Modbus message.
Output Status: "OFF" when the output is off
 "ON" when the output is on.

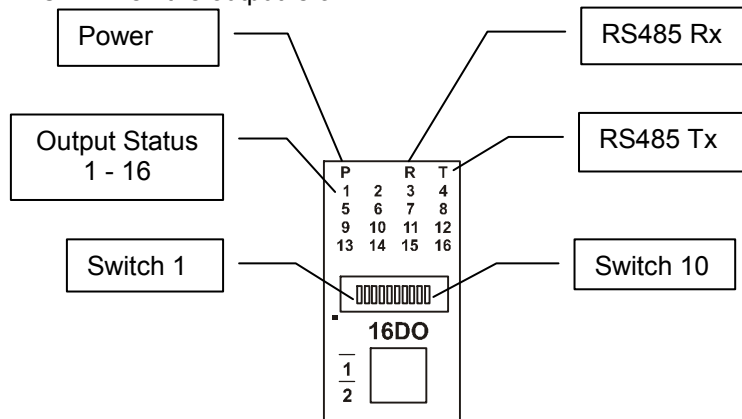

3.2.4 Wiring

The following diagram shows how the digital outputs are connected to the coil of a relay. The coil is connected to positive and switched to negative.

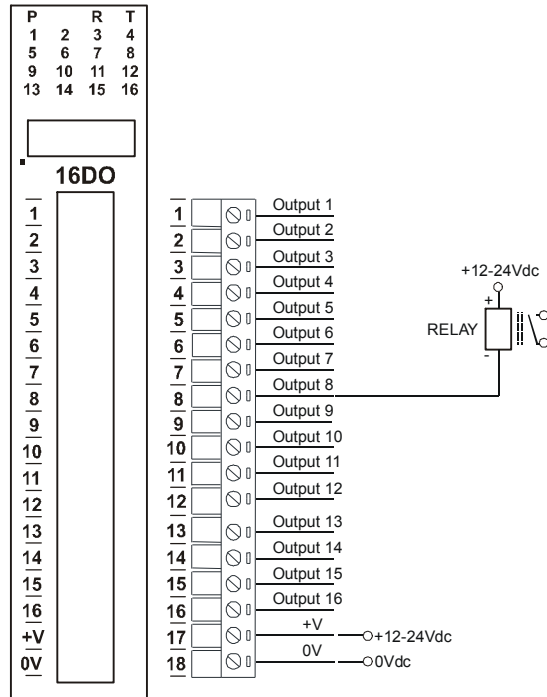

The following diagram shows the wiring for the power and RS485 communications.

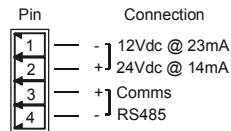

Note: If power/communication connections are reversed, module may become faulty.

3.2.5 Switch Setting

SWITCH	FUNCTION	DESCRIPTION
1	NODE ID +1	Node ID's from 0 to 127 are set up using switches 1 to 7
2	NODE ID +2	"
3	NODE ID +4	"
4	NODE ID +8	"
5	NODE ID +16	"
6	NODE ID +32	"
7	NODE ID +64	"
8	-	Not Used.
9	MODE	Slave (Off)
10	BAUD RATE	Selects 9600 (off) or Programmed Baud Rate (on)

3.2.6 IO-16DO Data Registers (MODULE TYPE = 101)

Modbus Address	Register Name	Low Limit	High Limit	Access	Comments
00001	Digital Output 1	0	1	R/W	Status of Digital Outputs.
00002	Digital Output 2	0	1	R/W	"
00003	Digital Output 3	0	1	R/W	"
00004	Digital Output 4	0	1	R/W	"
00005	Digital Output 5	0	1	R/W	"
00006	Digital Output 6	0	1	R/W	"
00007	Digital Output 7	0	1	R/W	"
00008	Digital Output 8	0	1	R/W	"
00009	Digital Output 9	0	1	R/W	"
00010	Digital Output 10	0	1	R/W	"
00011	Digital Output 11	0	1	R/W	"
00012	Digital Output 12	0	1	R/W	"
00013	Digital Output 13	0	1	R/W	"
00014	Digital Output 14	0	1	R/W	"
00015	Digital Output 15	0	1	R/W	"
00016	Digital Output 16	0	1	R/W	"
30001	S/W Version / Module Type	N/A	N/A	R	High Byte = Software Version Low Byte = 101
40002	Digital Outputs	N/A	N/A	R/W	Digital Outputs in bits. 16(msb) – 1(lsb).
30100	DIP Switch	0	65535	R	Status of DIP Switch on Front Panel
40101	Watchdog Timer	0	255	R/W	Timer in seconds. 0 = disabled. 1 - 255 = enabled.
40121	Baud Rate	2400	11520	R/W	2400, 4800, 9600,19200, 38400,57600,115200
40122	Parity	0	2	R/W	0 = none, 1 = even, 2 = odd
40123	Stop Bits	1	2	R/W	1 = 1 stop bit, 2 = 2 stop bits
40124	Reply Delay	0	65535	R/W	0 = Disable, >0 = Enable. (x10ms)

3.2.6.1 Digital Output Register.

The digital outputs can be read /written in a single register as follows

IO-16DO DIGITAL OUTPUTS															ADDRESS	
MSB																LSB
15	14	13	12	11	10	9	8	7	6	5	4	3	2	1	0	40002
32768	16384	8192	4096	2048	1024	512	256	128	64	32	16	8	4	2	1	
16	15	14	13	12	11	10	9	8	7	6	5	4	3	2	1	

Digital Output

3.2.6.2 Output Watchdog Timer

The watchdog timer is used to switch off all of the outputs in the event of a communications failure. When set to zero (register 40101) the watchdog timer is disabled.

3.3 IO-4RO - RELAY OUTPUTS

3.3.1 Description

The IO-4RO module has 4 normally open/ normally closed relay outputs. These modules may be used when a higher drive capability is required, or when isolation between outputs are required.

When switch 9 is off, the module is configured as a slave module for the Modbus master device such as a PC / PLC / HMI. When used as a slave module, the outputs are written to by the Modbus master device such as a PC/PLC/HMI. Each output can be individually switched on or off, or all outputs can be set up at the same time by writing a single number to the output register which represents the status of all outputs.

An output watchdog timer can be configured to switch off all the outputs if there has been no communications with the module for up to 255 seconds. A value of 0 seconds will disable this timer and the outputs will remain in the last programmed state.

3.3.2 Technical Specification of IO-4RO

Power Supply	Logic Supply Voltage	24 Vdc
	Logic Supply Current	42 mA
Relay Outputs	Output Points	4
	Maximum Current	0.5A @ 220VAC / 1A @ 28VDC
	Isolation	1000Vrms between field and logic 1000Vrms between outputs
Temperature	Operating Temperature.	-10°C to + 50°C
	Storage Temperature	-40°C to + 85°C
Connectors	Logic Power and Comms.	4 Pin Connector on underside of unit
	Outputs	18 Way screw connector on front

3.3.3 Status Indicators

- Power:** Flashes to indicate the CPU is running.
- RS485 Rx:** Flashes to indicate the unit has received a valid Modbus message.
- RS485 Tx:** Flashes to indicate the unit has sent a Modbus message.
- Output Status:** "OFF" when the output is off
"ON" when the output is on.

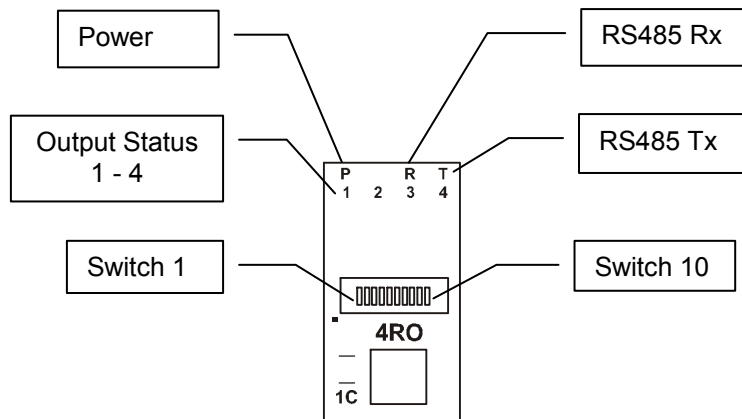

3.3.4 Wiring

The following diagram shows how the digital outputs are connected to the coil of a relay. The coil is connected to positive and switched to negative.

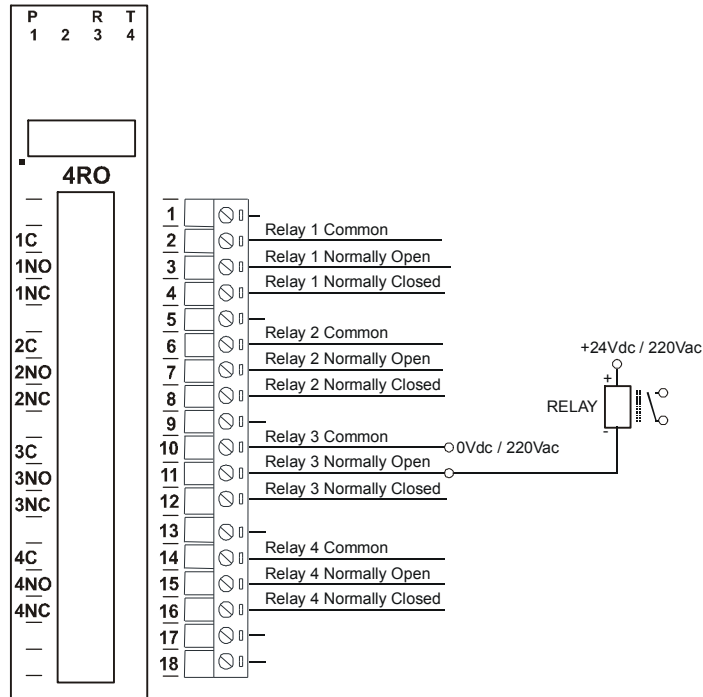

The following diagram shows the wiring for the power and RS485 communications.

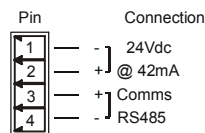

Note: If power/communication connections are reversed, module may become faulty.

3.3.5 Switch Setting

SWITCH	FUNCTION	DESCRIPTION
1	NODE ID +1	Node ID's from 0 to 127 are set up using switches 1 to 7
2	NODE ID +2	"
3	NODE ID +4	"
4	NODE ID +8	"
5	NODE ID +16	"
6	NODE ID +32	"
7	NODE ID +64	"
8	-	Not Used.
9	MODE	Slave (Off)
10	BAUD RATE	Selects 9600 (off) or Programmed Baud Rate (on)

3.3.6 IO-4RO Data Registers (MODULE TYPE = 113)

Modbus Address	Register Name	Low Limit	High Limit	Access	Comments
00001	Relay Output 1	0	1	R/W	Status of Digital Outputs.
00002	Relay Output 2	0	1	R/W	"
00003	Relay Output 3	0	1	R/W	"
00004	Relay Output 4	0	1	R/W	"
30001	S/W Version / Module Type	N/A	N/A	R	High Byte = Software Version Low Byte = 113
40002	Digital Outputs	N/A	N/A	R/W	Digital Outputs in bits. 4(msb) – 1(lsb).
30100	DIP Switch	0	65535	R	Status of DIP Switch on Front Panel
40101	Watchdog Timer	0	255	R/W	Timer in seconds. 0 = disabled. 1 - 255 = enabled.
40121	Baud Rate	2400	11520	R/W	2400, 4800, 9600,19200, 38400,57600,115200
40122	Parity	0	2	R/W	0 = none, 1 = even, 2 = odd
40123	Stop Bits	1	2	R/W	1 = 1 stop bit, 2 = 2 stop bits
40124	Reply Delay	0	65535	R/W	0 = Disable, >0 = Enable. (x10ms)

3.3.6.1 Relay Output Register

The relay outputs can be read /written in a single register as follows

MSB		IO-4RO DIGITAL OUTPUTS												LSB		ADDRESS
15	14	13	12	11	10	9	8	7	6	5	4	3	2	1	0	
32768	16384	8192	4096	2048	1024	512	256	128	64	32	16	8	4	2	1	40002
-	-	-	-	-	-	-	-	-	-	-	-	-	4	3	2	1

Relay Output

3.3.6.2 Output Watchdog Timer

The watchdog timer is used to switch off all of the outputs in the event of a communications failure. When set to zero (register 40101) the watchdog timer is disabled.

3.4 IO-8DIO - DIGITAL INPUTS / OUTPUTS

3.4.1 Description

The IO-8DIO module is an 8 channel digital input and 8 channel digital output module.

The inputs are isolated from the logic by bi-directional opto-couplers. The common is connected internally to either the -volts or +volts field power supply terminals using a jumper link which is situated inside the housing.

The inputs have internal counters associated with them. These counters are 32 bit counters allowing a count value from 0 to 4294967295. The count value can be cleared by writing a zero to the associated registers or preset to any other value using the same method. The counters can also be reset automatically when read. This is done by setting on DIP switch 9 on the front panel.

Note: The count values are not battery backed-up and will be lost if power is turned off.

The format of the registers allows the status of the inputs to be read as either single bits or all at once as a single register on the Modbus network.

The 8 digital outputs are open collector (NPN). The outputs may be used to drive lamps or external relays when more drive capability is required. The outputs are isolated from the logic and they share a common negative terminal.

The module may be configured as slave, where PC/ PLC/ HMI acting as master on the Modbus network. Dip switch 9 should be switched off to make this module as slave. Each output on the module can be individually switched on or off, or all outputs can be set up at the same time by writing a single number to the output register which represents the status of all outputs.

3.4.2 Technical Specification of IO-DIO

Power Supply	Logic Supply Voltage	12 -24 Vdc
	Logic Supply Current	33mA @ 12V / 19mA @ 24V
	Field Supply Voltage	12 -24 Vdc
	Field Supply Current	6mA @ 12V / 6mA @ 24V
Digital Inputs	Input Points	8
	Input Voltage Range	12 -24 Vdc
	Input Current per input	5mA@12Vdc / 11mA @24Vdc
	Isolation	1500Vrms between field and logic
Digital Outputs	Output Points	8
	Maximum Voltage	36 Vdc
	Maximum Current	100 mA per output
	Vceon	1.1V Max.
	Isolation	1500Vrms between field and logic
Counters	Inputs	1 to 16
	Resolution	32 Bits
	Frequency	1KHz (max)
	Pulse Width	500us (min)
Temperature	Operating Temperature.	-10°C to + 50°C
	Storage Temperature	-40°C to + 85°C
Connectors	Logic Power and Comms.	4 Pin Connector on underside of unit
	Outputs	18 Way screw connector on front

Note: Inputs 1 to 8 are used as both digital inputs and counter inputs.

3.4.3 Status Indicators

- Power:** Flashes to indicate the CPU is running.
- RS485 Rx:** Flashes to indicate the unit has received a valid Modbus message.
- RS485 Tx:** Flashes to indicate the unit has sent a Modbus message.
- Input Status:** "OFF" when the input is off
"ON" when the input is on.
- Output Status:** "OFF" when the output is off
"ON" when the output is on.

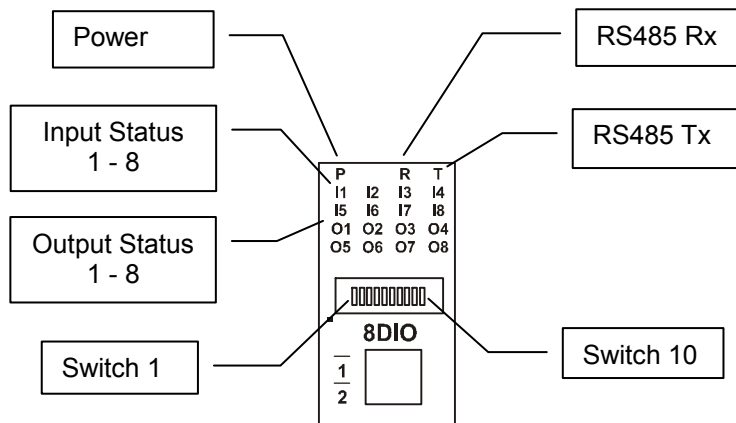

3.4.4 Wiring

The following diagram shows how the digital inputs and outputs are connected.

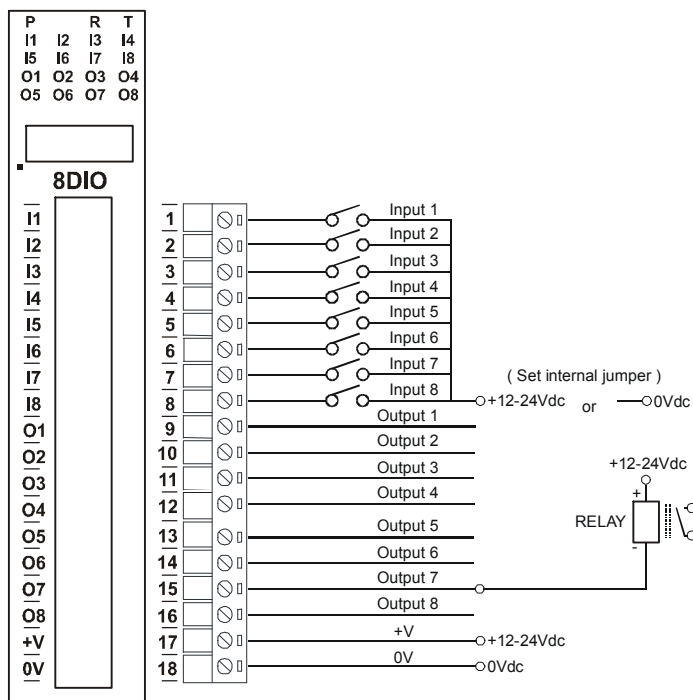

The following diagram shows the wiring for the power and RS485 communications.

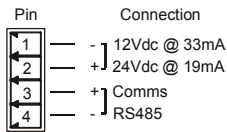

Note: If power/communication connections are reversed, module may become faulty.

3.4.5 Switch Settings

SWITCH	FUNCTION	DESCRIPTION
1	NODE ID +1	Node ID's from 0 to 127 are set up using switches 1 to 7
2	NODE ID +2	"
3	NODE ID +4	"
4	NODE ID +8	"
5	NODE ID +16	"
6	NODE ID +32	"
7	NODE ID +64	"
8	INVERT	When switched ON the status of the inputs is inverted in the Modbus status register (30002).
9	MODE	Off (Slave)
10	BAUD RATE	Selects 9600 (off) or Programmed Baud Rate (on)

3.4.6 Jumper Settings

The Digital inputs can be configured as NPN inputs. This means that the inputs can be operated by switching to 0V. Open the IO Module. Change the link **LK1** to the NPN position as shown below.

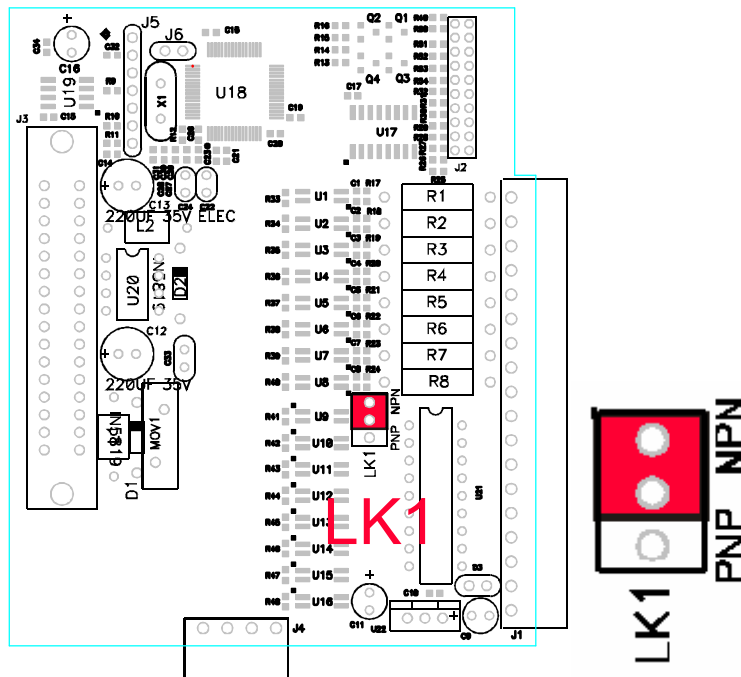

The Digital inputs can be configured as PNP inputs. This means that the inputs can be operated by switching to +12V to +24V. Open the IO Module. Change the link **LK1** to the PNP position as shown below.

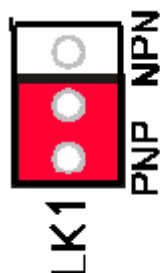

3.4.7 IO-8DIO Data Registers (MODULE TYPE = 102)

Modbus Address	Register Name	Low Limit	High Limit	Access	Comments
10001	Digital Input 1	0	1	R	Status of Digital Inputs.
10002	Digital Input 2	0	1	R	"
10003	Digital Input 3	0	1	R	"
10004	Digital Input 4	0	1	R	"
10005	Digital Input 5	0	1	R	"
10006	Digital Input 6	0	1	R	"
10007	Digital Input 7	0	1	R	"
10008	Digital Input 8	0	1	R	"
00017	Digital Output 1	0	1	R/W	Status of Digital Outputs.
00018	Digital Output 2	0	1	R/W	"
00019	Digital Output 3	0	1	R/W	"
00020	Digital Output 4	0	1	R/W	"
00021	Digital Output 5	0	1	R/W	"
00022	Digital Output 6	0	1	R/W	"
00023	Digital Output 7	0	1	R/W	"
00024	Digital Output 8	0	1	R/W	"
30001	S/W Version / Module Type	N/A	N/A	R	High Byte = Software Version Low Byte = 102
30002	Digital Inputs	N/A	N/A	R	Digital Inputs in lower 8 bits. 8 - 1.
40003	Digital Outputs	N/A	N/A	R/W	Digital Outputs in lower 8 bits. 8 - 1.
40004	Counter 1 MSB	0	65535	R/W	Counter MSB and LSB combine to give a 32 bit
40005	Counter 1 LSB	0	65535	R/W	Counter with range 0 to 4294967295.
40006	Counter 2 MSB	0	65535	R/W	"
40007	Counter 2 LSB	0	65535	R/W	"
40008	Counter 3 MSB	0	65535	R/W	"
40009	Counter 3 LSB	0	65535	R/W	"
40010	Counter 4 LSB	0	65535	R/W	"

40011	Counter 4 LSB	0	65535	R/W	"
40012	Counter 5 MSB	0	65535	R/W	"
40013	Counter 5 LSB	0	65535	R/W	"
40014	Counter 6 MSB	0	65535	R/W	"
40015	Counter 6 LSB	0	65535	R/W	"
40016	Counter 7 MSB	0	65535	R/W	"
40017	Counter 7 LSB	0	65535	R/W	"
40018	Counter 8 MSB	0	65535	R/W	"
40019	Counter 8 LSB	0	65535	R/W	"
30100	DIP Switch	0	65535	R	Status of DIP Switch on Front Panel
40101	Watchdog Timer	0	255	R/W	Timer in seconds. 0 = disabled. 1 - 255 = enabled.
40105	Counter Mode	0	2	R/W	0=Disable, 1=Up Counting, 2=Up/Down Count
40106	Input Filter	0	65535	R/W	0 = Disable, >0 = Enable. (x10ms)
40121	Baud Rate	2400	11520	R/W	2400, 4800, 9600, 19200, 38400,57600,115200
40122	Parity	0	2	R/W	0 = none, 1 = even, 2 = odd
40123	Stop Bits	1	2	R/W	1 = 1 stop bit, 2 = 2 stop bits
40124	Reply Delay	0	65535	R/W	0 = Disable, >0 = Enable. (x10ms)

3.4.7.1 Digital Input Register.

The digital inputs can be read in a single register as follows:

IO-8DIO DIGITAL INPUTS															MSB	LSB	ADDRESS
15	14	13	12	11	10	9	8	7	6	5	4	3	2	1	0		
32768	16384	8192	4096	2048	1024	512	256	128	64	32	16	8	4	2	1	30002	
0	0	0	0	0	0	0	0	8	7	6	5	4	3	2	1		

Digital Input Number

3.4.7.2 Digital Output Register

The digital outputs can be read /written in a single register as follows:

IO-8DIO DIGITAL OUTPUTS															MSB	LSB	ADDRESS
15	14	13	12	11	10	9	8	7	6	5	4	3	2	1	0		
32768	16384	8192	4096	2048	1024	512	256	128	64	32	16	8	4	2	1	40003	
0	0	0	0	0	0	0	0	8	7	6	5	4	3	2	1		

Digital Output Number

3.4.7.3 Counter Registers.

The counters are stored a two 16 bit registers. The first register is the High Register and the second register is the Low Register. To get the actual 32 bit count value the registers must be combined as follows:

Counter High Value = Register 40003.

Counter Low Value = Register 40004.

Counter Value = (Counter High Value X 65535) + Counter Low Value.

3.4.7.4 Output Watchdog Timer

The watchdog timer is used to switch off all of the outputs in the event of a communications failure. When set to zero (register 40101) the watchdog timer is disabled.

3.5 IO-8AI and IO-8AIV - ANALOG INPUTS

3.5.1 Description

The Analog Input modules are supplied as either a current input module (IO8AI) or a voltage input module (IO-AIV). The inputs are isolated from the logic and share a common negative terminal.

The standard setting for the IO-8AI module is 0 - 20mA input current which represents an output value of 0 - 4095 (12 bits) in the corresponding Modbus register. To obtain an output value of 0 to 4095 for an input signal of 4 to 20mA the offset switch is switched on.

The same applies to the IO-8AIV module. An input voltage of 0 - 10Volts represents an output of 0 - 4095 and 2 volts would give a reading of $819 \pm 1\text{LSB}$. To obtain an output value of 0 to 4095 for an input signal of 2 to 10V the offset switch is switched on. An input range of 0(1) to 5Vdc is available by removing the jumper link located on the analogue board inside the enclosure.

3.5.2 Technical Specification of IO-8AI

Power Supply	Logic Supply Voltage	12 -24 Vdc
	Logic Supply Current	27mA @ 12V / 16mA @ 24V
	Field Supply Voltage	12 -24 Vdc
	Field Supply Current	8mA @ 12V / 15mA @ 24V
Voltage Inputs – IO-8AIV	Input Points	8
	Input Voltage	0(2) - 10 Vdc or 0(1) - 5 Vdc
	Input Resistance	20kohms
	Resolution	12 bits
	Drift	50ppm/°C
	Accuracy	0.2% of span
	Isolation	1500Vrms between field and logic
Current Inputs – IO-8AI	Input Points	8
	Input Current	0(4) - 20 mA
	Input Resistance	250ohms
	Resolution	12 bits
	Drift	50ppm/°C
	Accuracy	0.2% of span
	Isolation	1500Vrms between field and logic
Temperature	Operating Temperature.	-10°C to + 50°C
	Storage Temperature	-40°C to + 85°C
Connectors	Logic Power and Comms.	4 Pin Connector on underside of unit
	Inputs	18 Way screw connector on front

3.5.3 Status Indicators

Power: Flashes to indicate the CPU is running.
RS485 Rx: Flashes to indicate the unit has received a valid Modbus message.
RS485 Tx: Flashes to indicate the unit has sent a Modbus message.

Input Status: “ON” when the input is zero.
 “OFF” when the input is greater than zero and less than 4095.
 “Flashing” when the input is over range, greater or equal to 4095

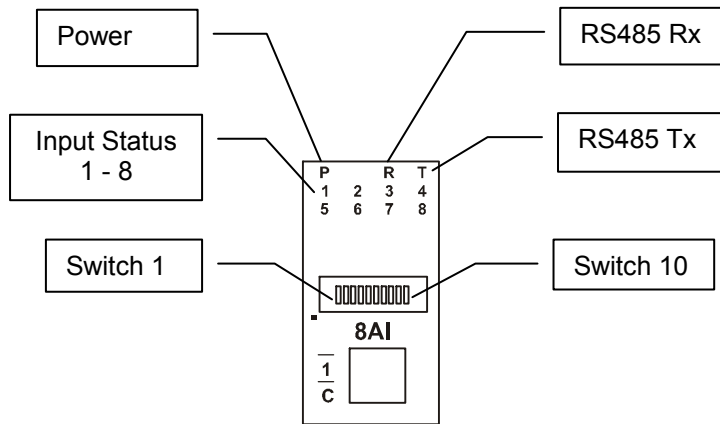

3.5.4 Wiring

The following diagram shows how the analog inputs are connected to a 0(4)-20mA source. All of the common terminals are connected together, and are connected to 0V internally.

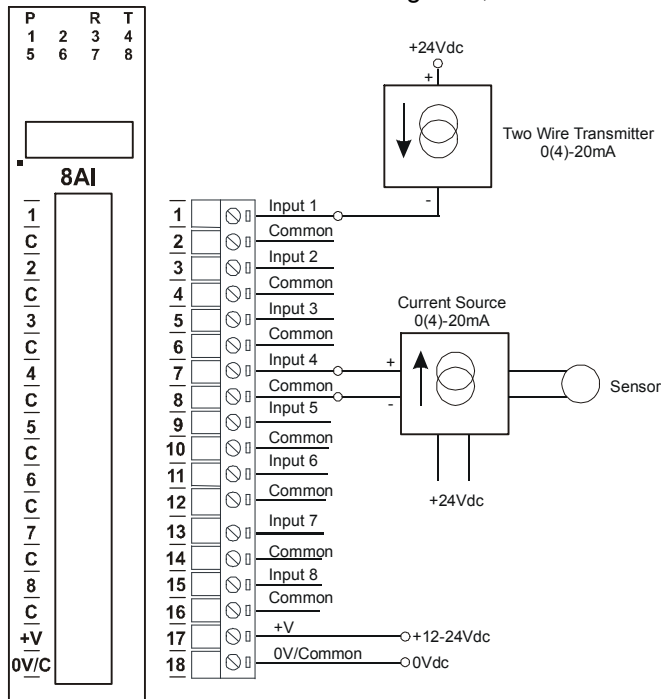

The following diagram shows how the analog inputs are connected to a 0(2)-10Vdc source. All of the common terminals are connected together, and are connected to 0V internally.

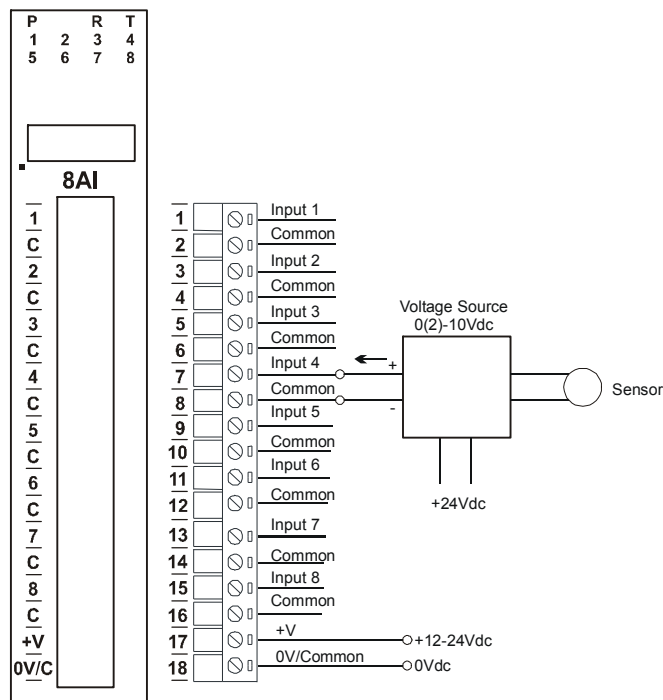

The following diagram shows the wiring for the power and RS485 communications.

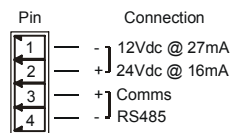

Note: If power/communication connections are reversed, module may become faulty.

3.5.5 Switch Settings

SWITCH	FUNCTION	DESCRIPTION
1	NODE ID +1	Node ID's from 0 to 127 are set up using switches 1 to 7
2	NODE ID +2	"
3	NODE ID +4	"
4	NODE ID +8	"
5	NODE ID +16	"
6	NODE ID +32	"
7	NODE ID +64	"
8	-	Not used.
9	OFFSET	When switched ON the inputs scaled to accept a 2V or 4mA offset
10	BAUD RATE	Selects 9600 (off) or Programmed Baud Rate (on)

3.5.6 IO-8AI Data Registers (IO8AI TYPE = 103 / IO-8AIV TYPE = 104)

Modbus Address	Register Name	Low Limit	High Limit	Access	Description
30001	S/W Version / Module Type	N/A	N/A	R	High Byte = Software Version Low Byte = 103(IO-8AI) or 104(IO-8AIV)
30002	Analog Input 1	0	4095	R	Analog Input lower 12 Bits
30003	Analog Input 2	0	4095	R	"
30004	Analog Input 3	0	4095	R	"
30005	Analog Input 4	0	4095	R	"
30006	Analog Input 5	0	4095	R	"
30007	Analog Input 6	0	4095	R	"
30008	Analog Input 7	0	4095	R	"
30009	Analog Input 8	0	4095	R	"
30010	Input Status	0	65535	R	bit2 = 0(open circuit or < 2), bit2 = 1(over range) bit1 = 0(OK),bit1 = 1(error)
30100	DIP Switch	0	65535	R	Status of DIP Switch on Front Panel
40121	Baud Rate	2400	11520	R/W	2400, 4800, 9600, 19200, 38400,57600,115200
40122	Parity	0	2	R/W	0 = none, 1 = even, 2 = odd
40123	Stop Bits	1	2	R/W	1 = 1 stop bit, 2 = 2 stop bits
40124	Reply Delay	0	65535	R/W	0 = Disable, >0 = Enable. (x10ms)

3.5.6.1 Analog Input Registers.

The analog inputs are read as a 12 bit value in the registers as follows:

IO-8AI ANALOG INPUTS															MSB	LSB	ADDRESS
15	14	13	12	11	10	9	8	7	6	5	4	3	2	1	0		
32768	16384	8192	4096	2048	1024	512	256	128	64	32	16	8	4	2	1		300XX
0	0	0	0	x	x	x	x	x	x	x	x	x	x	x	x		

Analog Input: 12 Bit Value (0 - 4095)

3.5.6.2 Analog Input Status

There are two status bits associated with each analog input. These bits are used to indicate if the input is zero or open circuit, in the working range 0-4095, or over range. If the input is open circuit or over range, then the error bit will be set. When the error bit is set, the range bit is zero if the input is open circuit and set if the input is over range, ie.,

<u>Bit 1- Error</u>	<u>Bit 2-Range</u>	<u>Condition</u>	<u>Status LED</u>
0	don't care	Input working OK	(LED OFF)
1	0	Input Open circuit or zero	(LED ON)
1	1	Input Over range	(LED FLASH)

The analog input status can be read in a single register as follows:

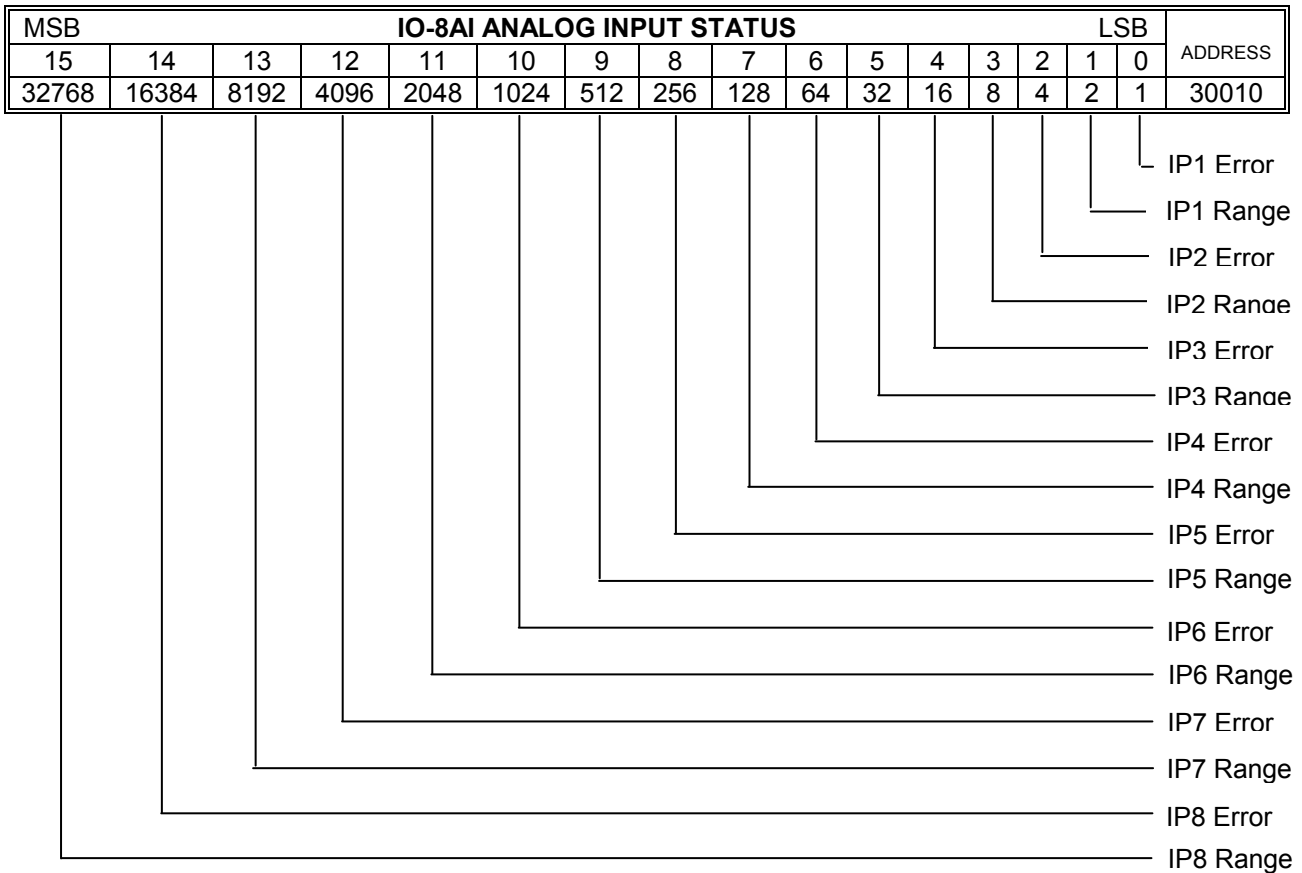

3.6 IO-8AIIS and IO-8AIVS - ISOLATED ANALOG INPUTS

3.6.1 Description

The Analog Input modules are supplied as either a current input module (IO-8AIIS) or a voltage input module (IO-8AIVS). The inputs are fully isolated from input to logic and between inputs. This module is ideal for monitoring existing 4-20mA current loops which are isolated from each other and cannot be connected to a common point of reference.

The standard setting for the IO-8AIIS module is 0 - 20mA input current which represents an output value of 0 - 4095 (12 bits) in the corresponding Modbus register. To obtain an output value of 0 to 4095 for an input signal of 4 to 20mA the offset switch is switched on. This module can also be configured for a 0 – 20.000mA input range or +/- 20.000mA input.

The same applies to the IO-8AIV module. An input voltage of 0 - 10Volts represents an output of 0 - 4095 and 2 volts would give a reading of $819 \pm 1\text{LSB}$. To obtain an output value of 0 to 4095 for an input signal of 2 to 10V the offset switch is switched on. This module can also be configured for a 0 – 10.000V input range or +/- 10.000V input.

3.6.2 Technical Specification of IO-8AIIIS and IO-8AIVS

Power Supply	Logic Supply Voltage	12 -24 Vdc	
	Logic Supply Current	58mA @ 12V / 31mA @ 24V	
Voltage Inputs – IO-8AIVS	Input Points	8	
	Input Voltage	0(2) - 10 Vdc	
	InputType	Range	Resolution
	1	0 – 4095	12 bits
	2	0 – 10.000 V	1Mv
	3	+/- 10.000 V	1mV
	4	0 – 1.0000 V	0.1mV
	5	+/- 1.0000 V	0.1mV
	Drift	100ppm/°C	
	Isolation	1500Vrms between field and logic 350Vpeak between each input	
Current Inputs – IO-8AIIIS	Input Points	8	
	Input Current	0(4) - 20 mA	
	InputType	Range	Resolution
	1	0 – 4095	12 bits
	2	0–20.000mA	1uA
	3	+/-20.000mA	1uA
	Drift	100ppm/°C	
	Isolation	1000Vrms between field and logic 350Vpeak between each input	
Temperature	Operating Temperature.	-10°C to + 50°C	
	Storage Temperature	-40°C to + 85°C	
Connectors	Logic Power and Comms.	4 Pin Connector on underside of unit	
	Inputs	18 Way screw connector on front	

3.6.3 Status Indicators

- Power:** Flashes to indicate the CPU is running.
- RS485 Rx:** Flashes to indicate the unit has received a valid Modbus message.
- RS485 Tx:** Flashes to indicate the unit has sent a Modbus message.
- Input Status:** “ON” when the input is zero.
“OFF” when the input is greater than zero and less than 4095.
“Flashing” when the input is over range, greater or equal to 4095

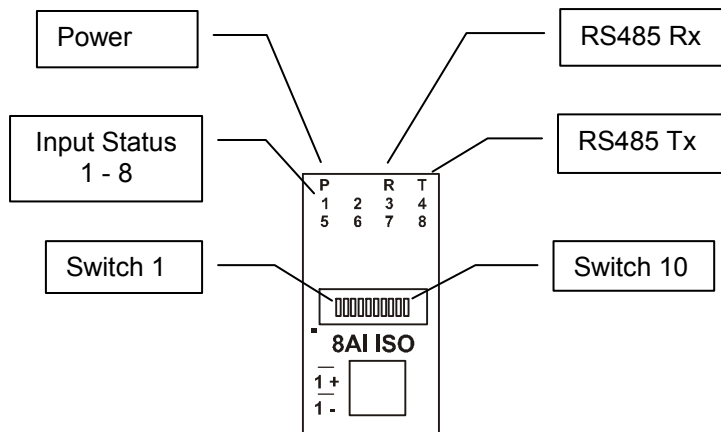

3.6.4 Wiring

The following diagram shows how the analog inputs are connected to a 0(4)-20mA source. All of the common terminals are isolated from each other.

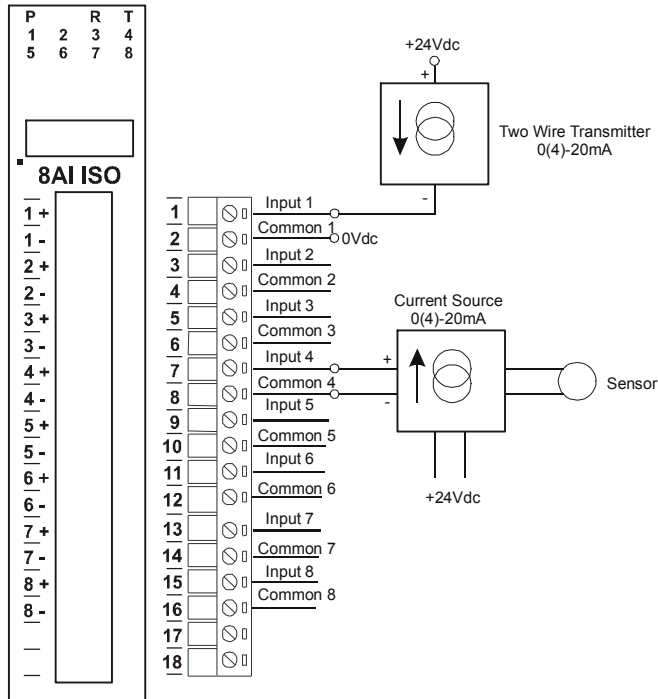

The following diagram shows how the analog inputs are connected to a 0(2)-10Vdc source. All of the common terminals are isolated from each other.

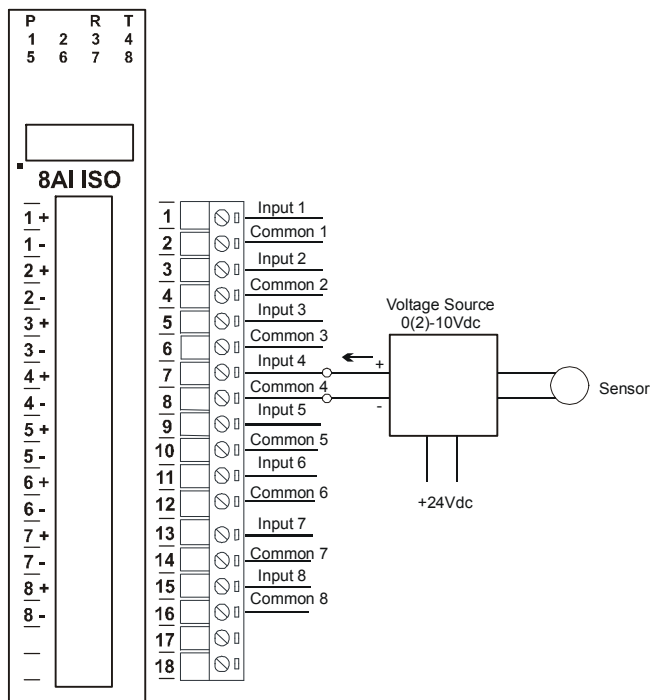

The following diagram shows the wiring for the power and RS485 communications.

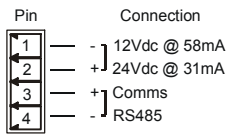

Note: If power/communication connections are reversed, module may become faulty.

3.6.5 Switch Settings

SWITCH	FUNCTION	DESCRIPTION
1	NODE ID +1	Node ID's from 0 to 127 are set up using switches 1 to 7
2	NODE ID +2	"
3	NODE ID +4	"
4	NODE ID +8	"
5	NODE ID +16	"
6	NODE ID +32	"
7	NODE ID +64	"
8	OFF SET	When switched ON the inputs scaled to accept a 2V or 4mA offset
9	BREAK	Input break. When switched off the analog value will be loaded with -32767 when the input is faulty. When switched on the analog value will be loaded with 32768
10	BAUD RATE	Selects 9600 (off) or Programmed Baud Rate (on)

3.6.6 IO-8AII Data Registers (8AII TYPE = 107/8AIV TYPE = 108)

Modbus Address	Register Name	Low Limit	High Limit	Access	Description
30001	S/W Version / Module Type	N/A	N/A	R	High Byte = Software Version Low Byte = 107(IO8AII) or 108(IO8AIV)
30002	Analog Input 1	0	4095	R	Analog Input lower 12 Bits
30003	Analog Input 2	0	4095	R	"
30004	Analog Input 3	0	4095	R	"
30005	Analog Input 4	0	4095	R	"
30006	Analog Input 5	0	4095	R	"
30007	Analog Input 6	0	4095	R	"
30008	Analog Input 7	0	4095	R	"
30009	Analog Input 8	0	4095	R	"
30010	Input Status	0	65535	R	bit2 = 0(open circuit or < 2), bit2 = 1(over range) bit1 = 0(OK),bit1 = 1(error)
30100	DIP Switch	0	65535	R	Status of DIP Switch on Front Panel
40121	Baud Rate	2400	11520	R/W	2400, 4800, 9600, 19200, 38400,57600,115200
40122	Parity	0	2	R/W	0 = none, 1 = even, 2 = odd
40123	Stop Bits	1	2	R/W	1 = 1 stop bit, 2 = 2 stop bits
40124	Reply Delay	0	65535	R/W	0 = Disable, >0 = Enable. (x10ms)

3.6.6.1 Analog Input Registers.

The analog inputs are read as a 12 bit value in the registers as follows:

MSB		IO-8AI ANALOG INPUTS												LSB		ADDRESS
15	14	13	12	11	10	9	8	7	6	5	4	3	2	1	0	
32768	16384	8192	4096	2048	1024	512	256	128	64	32	16	8	4	2	1	300XX
0	0	0	0	x	x	x	x	x	x	x	x	x	x	x	x	

Analog Input: 12 Bit Value (0 - 4095)

3.6.6.2 Analog Input Status

There are two status bits associated with each analog input. These bits are used to indicate if the input is zero or open circuit, in the working range 0-4095, or over range. If the input is open circuit or over range, then the error bit will be set. When the error bit is set, the range bit is zero if the input is open circuit and set if the input is over range, ie:

<u>Bit 1- Error</u>	<u>Bit 2-Range</u>	<u>Condition</u>	<u>Status LED</u>
0	don't care	Input working OK	(LED OFF)
1	0	Input Open circuit or zero	(LED ON)
1	1	Input Over range	(LED FLASH)

The analog input status can be read in a single register as follows:

MSB		IO-8AI ANALOG INPUT STATUS												LSB		ADDRESS
15	14	13	12	11	10	9	8	7	6	5	4	3	2	1	0	
32768	16384	8192	4096	2048	1024	512	256	128	64	32	16	8	4	2	1	30010

3.7 IO-8TC - THERMOCOUPLE INPUTS

3.7.1 Description

The IO-8TC module is a 8 thermocouple input module. The module uses differential inputs to reduce effects of electrical noise and mains pickup. The thermocouple inputs are isolated from the logic. If inter channel isolation is required then the IO-8TCS should be used.

The thermocouple voltage is read by the module circuitry, linearised and converted to degrees Centigrade. No ranging is required as the module covers the full range as indicated in the table of TC types. The value that is read from the Modbus register is the actual temperature in degrees centigrade to 0.1°C resolution. ie: a value of 3451 corresponds to a temperature of 345.1°C.

The thermocouple type is setup by writing a value to the TC Type register. The value is obtained from the table below. For example to select type K thermocouples, the value "2" must be written to the TC Type register. All 8 thermocouple inputs adopt the same TC type.

The DIP switch 9 is used to select upscale or downscale burnout. A value of 32768 is used to indicate upscale burnout and a value of -32767 is used to indicate downscale burnout.

The module has built in Cold Junction Compensation. Use must be made of the correct thermocouple extension wire to avoid reading errors.

The thermocouple module can also be configured for a 0 - 50mV input range. The TC Type register must be set to 9 for this option. The value in the register which is read back over the network is 0 - 50,000.

Note: As there is no inter-channel isolation, isolated thermocouples must be used in order to prevent ground loops and reading errors.

3.7.2 Technical Specification of IO-8TC

Power Supply	Logic Supply Voltage		12 -24 Vdc	
	Logic Supply Current		62mA @ 12V / 33mA @ 24V	
TC Inputs	Input Points		8	
	Resolution		0.1°C	
	Drift		100ppm/°C Typ.	
	Isolation		1500Vrms between field and logic	
TC Type	Number	Type	Range	Accuracy
	1	J	-150 to 760 °C	± 0.2°C
	2	K	-200 to 1370 °C	± 0.3°C
	3	E	0 to 600 °C	± 0.1°C
	4	T	-200 to 400 °C	± 0.3°C
	5	N	0 to 1300 °C	± 0.3°C
	6	B	400 to 1820 °C	± 0.5°C
	7	S	-50 to 1767 °C	± 0.6°C
	8	R	-50 to 1767 °C	± 0.7°C
	9	mV	0 to 50mV	± 0.1%
	10	C	0 to 2315.5 °C	± 0.7°C
	11	D	0 to 2315.5 °C	± 0.7°C
	12	G	0 to 2315.5 °C	± 0.9°C
13	m V	+/- 100mV	± 0.1%	

Cold Junction	CJC Error	±0.5°C Typ. After 30 Minutes warm up time.
Temperature	Operating Temperature.	-10°C to + 50°C
	Storage Temperature	-40°C to + 85°C
Connectors	Logic Power and Comms.	4 Pin Connector on underside of unit
	Inputs	18 Way screw connector on front

3.7.3 Status Indicators

- Power:** Flashes to indicate the CPU is running.
- RS485 Rx:** Flashes to indicate the unit has received a valid Modbus message.
- RS485 Tx:** Flashes to indicate the unit has sent a Modbus message.
- Input Status:** "ON" when the thermocouple is open circuit.
"OFF" when the thermocouple is connected.

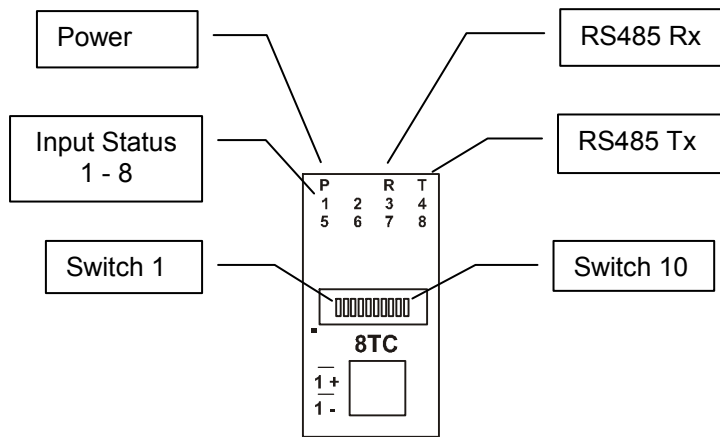

3.7.4 Wiring

The following diagram shows how the inputs are connected to a thermocouple.

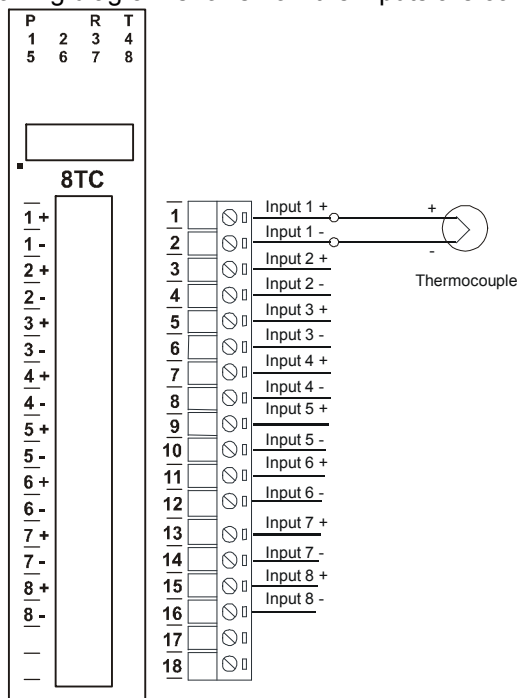

The following diagram shows the wiring for the power and RS485 communications.

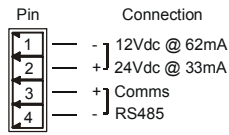

Note: If power/communication connections are reversed, module may become faulty.

3.7.5 Switch Settings

SWITCH	FUNCTION	DESCRIPTION
1	NODE ID +1	Node ID's from 0 to 127 are set up using switches 1 to 7
2	NODE ID +2	"
3	NODE ID +4	"
4	NODE ID +8	"
5	NODE ID +16	"
6	NODE ID +32	"
7	NODE ID +64	"
8	-	Not used.
9	BREAK	TC break. When switched off the TC value will be loaded with -32767 when the TC is faulty. When switched on the TC value will be loaded with 32768.
10	BAUD RATE	Selects 9600 (off) or Programmed Baud Rate (on)

3.7.6 IO-8TC Data Registers (MODULE TYPE = 105)

Modbus Address	Register Name	Low Limit	High Limit	Access	Description
30001	S/W Version / Module Type	N/A	N/A	R	High Byte = Software Version Low Byte = 105
30002	TC Input 1	-xxx.x	yyy.y	R	Thermocouple Inputs. See table for range.
30003	TC Input 2	-xxx.x	yyy.y	R	Resolution in 0.1°C.
30004	TC Input 3	-xxx.x	yyy.y	R	"
30005	TC Input 4	-xxx.x	yyy.y	R	"
30006	TC Input 5	-xxx.x	yyy.y	R	"
30007	TC Input 6	-xxx.x	yyy.y	R	"
30008	TC Input 7	-xxx.x	yyy.y	R	"
30009	TC Input 8	-xxx.x	yyy.y	R	"
30010	CJC Temp.	-xxx.x	yyy.y	R	CJC Temperature in 0.1°C resolution.
30011	Input Status	0	65535	R	bit1 = 0(OK),bit1 = 1(error or open circuit)
30100	DIP Switch	0	65535	R	Status of DIP Switch on Front Panel
40101	TC Type	1	13	R/W	See TC Tables.
40102	Line Frequency	50	60	R/W	Line Frequency
40103	CJC Offset	1	199	R/W	100 = zero offset (0.0)
40104	Units Type	1	2	R/W	1=°C, 2=°F
40121	Baud Rate	2400	11520	R/W	2400, 4800, 9600, 19200, 38400,57600,115200
40122	Parity	0	2	R/W	0 = none, 1 = even, 2 = odd
40123	Stop Bits	1	2	R/W	1 = 1 stop bit, 2 = 2 stop bits
40124	Reply Delay	0	65535	R/W	0 = Disable, >0 = Enable. (x10ms)

3.8 IO-8TCS - ISOLATED THERMOCOUPLE INPUTS

3.8.1 Description

The IO-8TCS module is a 8 isolated thermocouple input module. The module uses differential inputs to reduce effects of electrical noise and mains pickup. The thermocouple inputs are isolated from the logic and from each other. This module is operated in an identical way to the IO-8TC module and is fully interchangeable.

The thermocouple voltage is read by the module circuitry, linearised and converted to degrees Centigrade. No ranging is required as the module covers the full range as indicated in the TC table. The value that is read from the Modbus register is the actual temperature in degrees centigrade to 0.1°C resolution. ie: a value of 3451 corresponds to a temperature of 345.1°C.

The thermocouple type is setup by writing a value to the TC Type register. The value is obtained from the table below. For example to select type K thermocouples, the value "2" must be written to the TC Type register. All 8 thermocouple inputs adopt the same TC type.

The DIP switch 9 is used to select upscale or downscale burnout. A value of 32768 is used to indicate upscale burnout and a value of -32767 is used to indicate downscale burnout.

The module has built in Cold Junction Compensation. Use must be made of the correct thermocouple extension wire to avoid reading errors.

The thermocouple module can also be configured for a 0 - 50mV input range. The TC Type register must be set to 9 for this option. The value in the register which is read back over the network is 0 - 50,000.

3.8.2 Technical Specification of IO-8TCS

Power Supply	Logic Supply Voltage		12 -24 Vdc	
	Logic Supply Current		58mA @ 12V / 31mA @ 24V	
TC Inputs	Input Points		8	
	Resolution		0.1°C	
	Drift		100ppm/°C Typ.	
	Isolation		1500Vrms between field and logic 350Vpeak between each TC input	
TC Type	Number	Type	Range	Accuracy
	1	J	-150 to 760 °C	± 0.2°C
	2	K	-200 to 1370 °C	± 0.3°C
	3	E	0 to 600 °C	± 0.1°C
	4	T	-200 to 400 °C	± 0.3°C
	5	N	0 to 1300 °C	± 0.3°C
	6	B	400 to 1820 °C	± 0.5°C
	7	S	-50 to 1767 °C	± 0.6°C
	8	R	-50 to 1767 °C	± 0.7°C
	9	mV	0 to 50mV	± 0.1%
	10	C	0 to 2315.5 °C	± 0.7°C
	11	D	0 to 2315.5 °C	± 0.7°C
	12	G	0 to 2315.5 °C	± 0.9°C
13	m V	+/- 100mV	± 0.1%	

Cold Junction	CJC Error	±0.5°C Typ. After 30 Minutes warm up time.
Temperature	Operating Temperature.	-10°C to + 50°C
	Storage Temperature	-40°C to + 85°C
Connectors	Logic Power and Comms.	4 Pin Connector on underside of unit
	Inputs	18 Way screw connector on front

3.8.3 Status Indicators

- Power:** Flashes to indicate the CPU is running.
- RS485 Rx:** Flashes to indicate the unit has received a valid Modbus message.
- RS485 Tx:** Flashes to indicate the unit has sent a Modbus message.
- Input Status:** "ON" when the thermocouple is open circuit.
"OFF" when the thermocouple is connected.

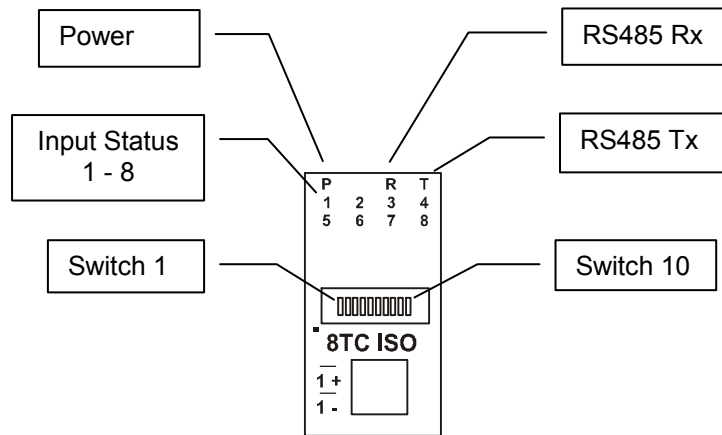

3.8.4 Wiring

The following diagram shows how the inputs are connected to a thermocouple.

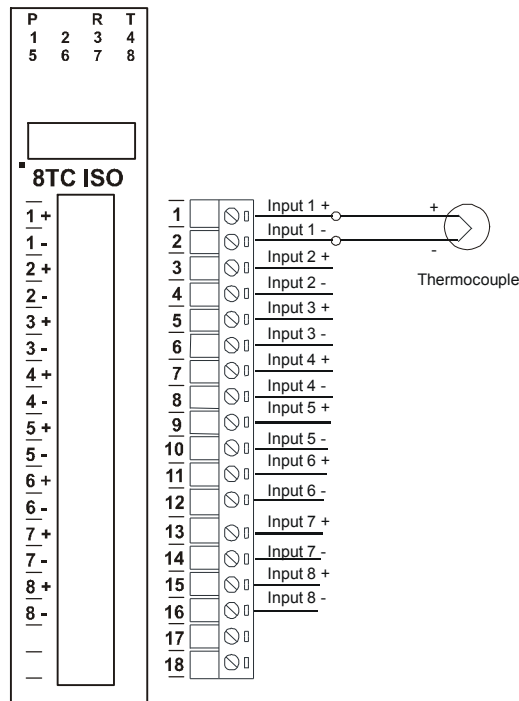

The following diagram shows the wiring for the power and RS485 communications.

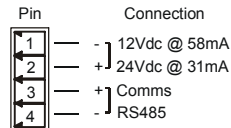

Note: If power/communication connections are reversed, module may become faulty.

3.8.5 Switch Settings

SWITCH	FUNCTION	DESCRIPTION
1	NODE ID +1	Node ID's from 0 to 127 are set up using switches 1 to 7
2	NODE ID +2	"
3	NODE ID +4	"
4	NODE ID +8	"
5	NODE ID +16	"
6	NODE ID +32	"
7	NODE ID +64	"
8	-	Not used.
9	BREAK	TC break. When switched off the TC value will be loaded with -32767 when the TC is faulty. When switched on the TC value will be loaded with 32768.
10	BAUD RATE	Selects 9600 (off) or Programmed Baud Rate (on)

3.8.6 IO-8TCS Data Registers (MODULE TYPE = 106)

Modbus Address	Register Name	Low Limit	High Limit	Access	Description
30001	S/W Version / Module Type	N/A	N/A	R	High Byte = Software Version Low Byte = 106
30002	TC Input 1	-xxx.x	yyy.y	R	Thermocouple Inputs. See table for range.
30003	TC Input 2	-xxx.x	yyy.y	R	Resolution in 0.1°C.
30004	TC Input 3	-xxx.x	yyy.y	R	"
30005	TC Input 4	-xxx.x	yyy.y	R	"
30006	TC Input 5	-xxx.x	yyy.y	R	"
30007	TC Input 6	-xxx.x	yyy.y	R	"
30008	TC Input 7	-xxx.x	yyy.y	R	"
30009	TC Input 8	-xxx.x	yyy.y	R	"
30010	CJC Temp.	-xxx.x	yyy.y	R	CJC Temperature in 0.1°C resolution.
30011	Input Status	0	65535	R	bit1 = 0(OK),bit1 = 1(error or open circuit)
30100	DIP Switch	0	65535	R	Status of DIP Switch on Front Panel
40101	TC Type	1	13	R/W	See TC Tables.
40102	Line Frequency	50	60	R/W	Line Frequency
40103	CJC Offset	1	199	R/W	100 = zero offset (0.0)
40104	Units Type	1	2	R/W	1=°C, 2=°F
40121	Baud Rate	2400	11520	R/W	2400, 4800, 9600, 19200, 38400,57600,115200
40122	Parity	0	2	R/W	0 = none, 1 = even, 2 = odd
40123	Stop Bits	1	2	R/W	1 = 1 stop bit, 2 = 2 stop bits
40124	Reply Delay	0	65535	R/W	0 = Disable, >0 = Enable. (x10ms)

3.9 IO-6RTD - RTD INPUTS

3.9.1 Description

The IO-6RTD module is a 6 RTD input module. The module can accommodate either 2 or 3 wire RTD sensors. The RTD inputs are isolated from the logic.

The RTD resistance is read by the module circuitry, linearised and converted to degrees Centigrade. No ranging is required as the module covers the full range of the RTD as indicated in the RTD table. The value that is read from the Modbus register is the actual temperature in degrees centigrade to 0.1°C resolution. ie: a value of 3451 corresponds to a temperature of 345.1°C.

The RTD type is setup by writing a value to the RTD Type register. The value is obtained from the table below. For example to select a PT100 RTD, the value "1" must be written to the RTD Type register. All 6 RTD inputs adopt the same RTD type.

The DIP switch 9 is used to select upscale or downscale burnout for break detection. A value of 32768 is used to indicate upscale burnout and a value of -32767 is used to indicate downscale burnout.

Note: As there is no inter-channel isolation, isolated RTD's must be used in order to prevent ground loops and reading errors.

3.9.2 Technical Specification of IO-6RTD

Power Supply	Logic Supply Voltage	12 -24 Vdc		
	Logic Supply Current	87mA @ 12V / 45mA @ 24V		
RTD Inputs	Input Points	6		
	RTD Configuration	2 or 3 Wire		
	Resolution	0.1°C		
	Drift	100ppm/°C Typ.		
	Line resistance effect	< 0.1°C balanced		
	Max. line resistance	100ohms		
	Isolation	1500Vrms between field and logic		
	RTD Type	Number	Type	Range
1		PT100	-200 to 850°C	± 0.3°C, IEC 751:1983
2		Ni120	-80 to 320°C	± 0.3°C
3		PT1000	-200 to 850°C	± 0.3°C
4		Ni1000-DIN	-200 to 850°C	± 0.3°C
5		Ni1000-Landys&Gyr	-200 to 850°C	± 0.3°C
6		Ohms	10 - 400 ohms	± 0.05%
7		Ohms	100-4000ohms	± 0.05%
Temperature	Operating Temperature.	-10°C to + 50°C		
	Storage Temperature	-40°C to + 85°C		
Connectors	Logic Power and Comms.	4 Pin Connector on underside of unit		
	Inputs	18 Way screw connector on front		

3.9.3 Status Indicators

- Power:** Flashes to indicate the CPU is running.
RS485 Rx: Flashes to indicate the unit has received a valid Modbus message.
RS485 Tx: Flashes to indicate the unit has sent a Modbus message.
Input Status: "ON" when the RTD is open circuit.
 "OFF" when the RTD is connected.

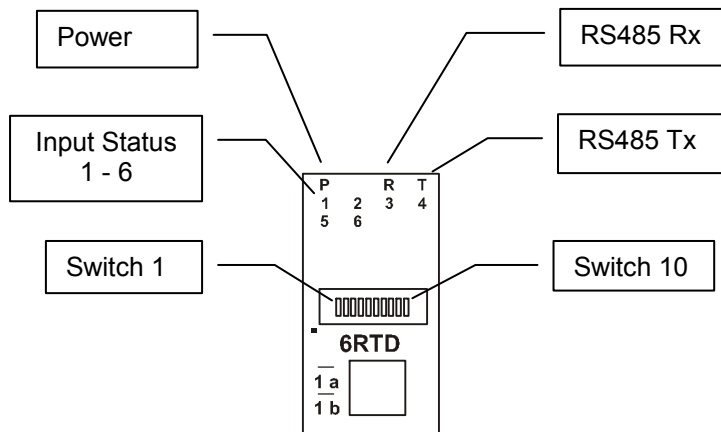

3.9.4 Wiring

The following diagram shows how the inputs are connected to a 2 and 3 wire RTD.

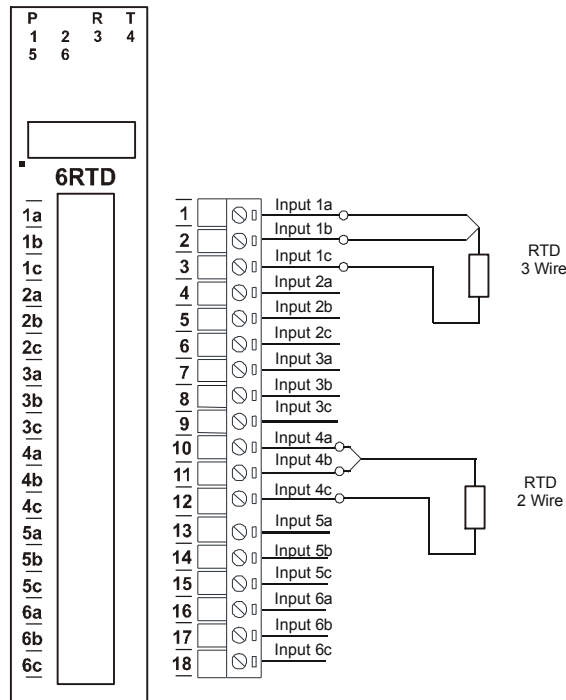

The following diagram shows the wiring for the power and RS485 communications.

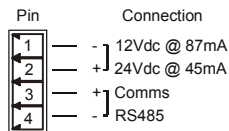

Note: If power/communication connections are reversed, module may become faulty.

3.9.5 Switch Settings

SWITCH	FUNCTION	DESCRIPTION
1	NODE ID +1	Node ID's from 0 to 127 are set up using switches 1 to 7
2	NODE ID +2	"
3	NODE ID +4	"
4	NODE ID +8	"
5	NODE ID +16	"
6	NODE ID +32	"
7	NODE ID +64	"
8	-	Not used.
9	BREAK	RTD break. When switched off the RTD value will loaded with -32767 when the RTD is faulty. When switched on the RTD value will be loaded with 32768.
10	BAUD RATE	Selects 9600 (off) or Programmed Baud Rate (on)

3.9.6 IO-6RTD Data Registers (MODULE TYPE = 109)

Modbus Address	Register Name	Low Limit	High Limit	Access	Description
30001	S/W Version / Module Type	N/A	N/A	R	High Byte = Software Version Low Byte = 109
30002	RTD Input 1	-xxx.x	yyy.y	R	RTD Inputs. See table for range.
30003	RTD Input 2	-xxx.x	yyy.y	R	Resolution in 0.1°C.
30004	RTD Input 3	-xxx.x	yyy.y	R	"
30005	RTD Input 4	-xxx.x	yyy.y	R	"
30006	RTD Input 5	-xxx.x	yyy.y	R	"
30007	RTD Input 6	-xxx.x	yyy.y	R	"
30008	Input Status	0	65535	R	bit1 = 0(OK),bit1 = 1(error or open circuit)
30100	DIP Switch	0	65535	R	Status of DIP Switch on Front Panel
40101	RTD Type	1	7	R/W	See RTD Tables.
40102	Line Frequency	50	60	R/W	Line Frequency
40103	Units Type	1	2	R/W	1=°C, 2=°F
40121	Baud Rate	2400	11520	R/W	2400, 4800, 9600, 19200, 38400,57600,115200
40122	Parity	0	2	R/W	0 = none, 1 = even, 2 = odd
40123	Stop Bits	1	2	R/W	1 = 1 stop bit, 2 = 2 stop bits
40124	Reply Delay	0	65535	R/W	0 = Disable, >0 = Enable. (x10ms)

3.9.6.1 RTD Input Status.

There is one status bits associated with each RTD input. These bits are used to indicate if the input is open circuit or over range. If the input is open circuit or over range, then the error bit will be set.

<u>Bit 1- Error</u>	<u>Bit 2-Not Used</u>	<u>Condition</u>	<u>Status LED</u>
0	0	Input working OK	(LED OFF)
1	0	Open circuit / Over range	(LED ON)

The analog input status can be read in a single register as follows

IO-6RTD ANALOG INPUT STATUS															ADDRESS		
MSB	15	14	13	12	11	10	9	8	7	6	5	4	3	2	1	0	LSB
	32768	16384	8192	4096	2048	1024	512	256	128	64	32	16	8	4	2	1	30008

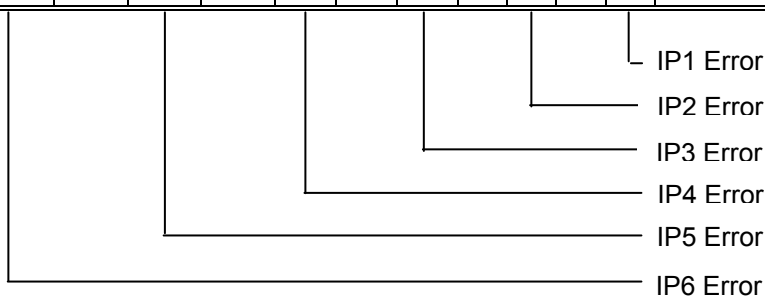

3.10 IO-DAIO – DIGITAL + ANALOG INPUTS AND OUTPUTS

3.10.1 Description

The IO-DAIO module is a multipurpose combination of inputs and outputs. The module can accommodate either 2 or 3 wire RTD sensors, current (0-20mA) and voltage (0-10V) inputs, current (0-20mA) or voltage (0-10V) output, and digital inputs and outputs.

RTD INPUTS:

There are 2 RTD inputs on the module. The RTD resistance is read by the module circuitry, linearised and converted to degrees Centigrade. No ranging is required as the module covers the full range of the RTD as indicated in the RTD table. The value that is read from the Modbus register is the actual temperature in degrees centigrade to 0.1°C resolution. ie: a value of 3451 corresponds to a temperature of 345.1°C.

The RTD type is setup by writing a value to the RTD Type register. The value is obtained from the table below. For example to select a PT100 RTD, the value "1" must be written to the RTD Type register.

A value of -32767 is used to indicate downscale burnout.

Note: As there is no inter-channel isolation, isolated RTD's must be used in order to prevent ground loops and reading errors.

ANALOG INPUTS:

The Analog Inputs (2) can be configured by internal jumpers as either a current input (0-20mA) or a voltage input (0-10V).

An input of 0 - 20mA input current or 0 – 10V input voltage represents an output value of 0 - 4095 (12 bits) in the corresponding Modbus register.

ANALOG OUTPUT:

There is a single analog output which can be configured with internal jumpers for a current output (0-20mA) or voltage output (0-10V).

The resolution is 12 bits, so writing a value to the Modbus register for each output of 0 - 4095 would give an output current of 0 - 20mA. A value of $819 \pm 1\text{LSB}$ will give a current output of 4mA.

DIGITAL INPUTS:

There are 4 digital inputs on the module. The inputs share a common terminal and can be configured for common positive or common negative.

The inputs have got counters associated with them. The counters operate in three modes.

In **mode 0** all the counters are disabled.

In **mode 1** all counters are 32 bit counters allowing a count value from 0 to 4294967295. The count value can be cleared by writing a zero to the associated registers or preset to any other value using the same method.

In **mode 2** the inputs are connected as up/down counters. Input 1 will increment counter 1 while input 2 decrements counter1.

Note: The count values are not battery backed-up and will be lost if power is turned off.

The format of the registers allows the status of the inputs to be read as either single bits or all at once as a single register on the Modbus network.

DIGITAL OUTPUTS:

The module has 2 open collector (NPN) digital outputs. The outputs may be used to drive lamps or external relays when more drive capability is required.

The outputs are written to by the Modbus master device such as a PC/ PLC/ HMI. Each output can be individually switched on or off, or all outputs can be set up at the same time by writing a single number to the output register which represents the status of all outputs.

An output watchdog timer can be configured to switch off all the outputs if there has been no communications with the module for up to 255 seconds. A value of 0 seconds will disable this timer and the outputs will remain in the last programmed state.

3.10.2 Technical Specification of IO-DAIO

Power Supply	Logic Supply Voltage		12 -24 Vdc	
	Logic Supply Current		115mA @ 12V / 58mA @ 24V	
	Field Supply Voltage		24 Vdc	
	Field Supply Current		25mA	
RTD Inputs	Input Points		2	
	RTD Configuration		2 or 3 Wire	
	Resolution		0.1°C	
	Drift		100ppm/°C Typ.	
	Line resistance effect		< 0.1°C balanced	
	Max. line resistance		100ohms	
	Isolation		1500Vrms between field and logic	
RTD Type	Number	Type	Range	Accuracy
	1	PT100	-200 to 850°C	± 0.3°CIEC 751:1983
	2	Ni120	-80 to 320°C	± 0.3°C
	3	PT1000	-200 to 850°C	± 0.3°C
	4	Ni1000-DIN	-200 to 850°C	± 0.3°C
	5	Ni1000- Landys&Gyr	-200 to 850°C	± 0.3°C
	6	Ohms	10 - 400 ohms	± 0.05%
	7	Ohms	100-4000ohms	± 0.05%
Current Inputs	Input Points		2	
	Input Current		0(4) - 20 mA	
	Input Resistance		250ohms	
	Input Type	Range	Resolution	
	1	0 – 4095	12 bits	
	2	0–20.000mA	1uA	

	3	+/-20.000mA	1uA
	Drift		100ppm/°C
	Accuracy		0.2% of span
	Isolation		1000Vrms between field and logic
Voltage Inputs	Input Points		2
	Input Voltage		0 - 1 Vdc or 0 – 10 Vdc
	Input Resistance		190kohms
	Input Type	Range	Resolution
	4	0 – 4095	12 bits
	5	0 – 10.000 V	1mV
	6	+/- 10.000 V	1mV
	7	0 – 1.0000 V	0.1mV
	8	+/- 1.0000 V	0.1mV
	Drift		100ppm/°C
	Accuracy		0.2% of span
	Isolation		1000Vrms between field and logic
	Current Output	Output Points	
Output Current		0(4) - 20 mA	
Output Type		Range	Resolution
1		0 – 4095	12 bits
Drift		100ppm/°C	
Accuracy		0.05% of span	
Compliance		1000 ohms max. @ 24Vdc 500 ohms max. @ 12Vdc	
Voltage Output		Output Points	
	Output Voltage		0(2) - 10 V
	Output Type	Range	Resolution
	2	0 – 4095	12 bits
	Drift		100ppm/°C
	Accuracy		0.05% of span
	Compliance		2000 ohms min. load
Digital Inputs	Input Points		4
	Input Voltage Range		10 - 26 Vdc
	Input Current per input		4mA@12Vdc / 8mA @24Vdc
Counters	Inputs		1 to 4
	Resolution		32 Bits
	Frequency		50 Hz (max)
	Pulse Width		20 ms (min)
Digital Outputs	Output Points		2
	Maximum Voltage		36 Vdc
	Maximum Current		100 mA per output
	Vceon		1.1V Max.
	Isolation		1500Vrms between field and logic
Temperature	Operating Temperature.		-10°C to + 50°C
	Storage Temperature		-40°C to + 85°C
Connectors	Logic Power and Comms.		4 Pin Connector on underside of unit
	Inputs		18 Way screw connector on front

3.10.3 Status Indicators

- Power:** "ON" when module has power.
- RS485 Rx:** Flashes to indicate the unit has received a valid Modbus message.
- RS485 Tx:** Flashes to indicate the unit has sent a Modbus message.

* Please note that LED status is not available for Digital and Analog IO's in IO-DAIO Module

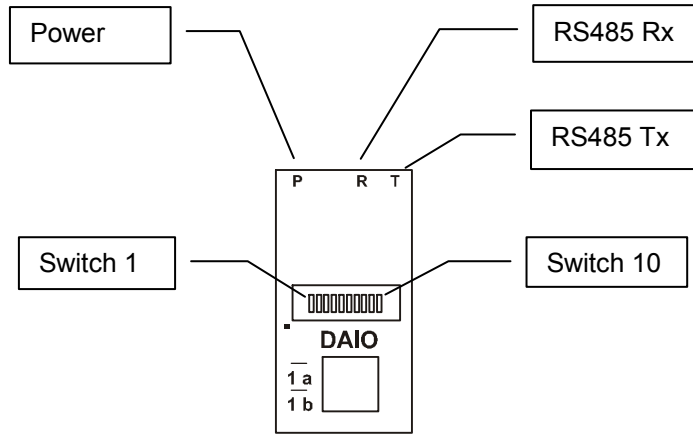

3.10.4 Wiring

The following diagram shows how the inputs and outputs are connected to the DAIO module.

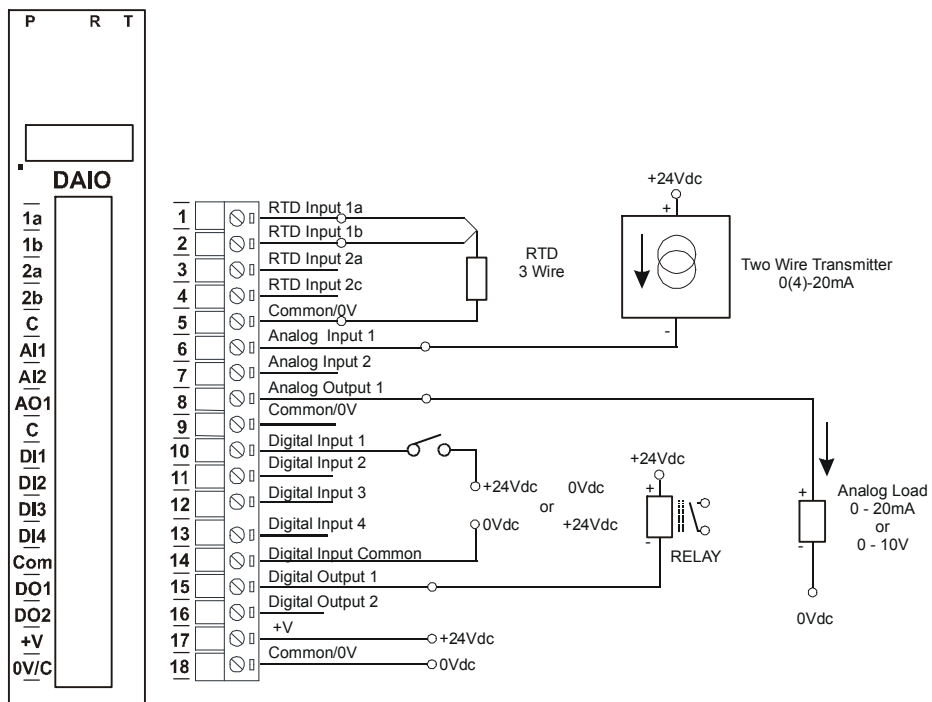

The following diagram shows the wiring for the power and RS485 communications.

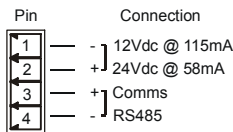

Note: If power/communication connections are reversed, module may become faulty.

3.10.5 Switch Settings

SWITCH	FUNCTION	DESCRIPTION
1	NODE ID +1	Node ID's from 0 to 127 are set up using switches 1 to 7
2	NODE ID +2	“
3	NODE ID +4	“
4	NODE ID +8	“
5	NODE ID +16	“
6	NODE ID +32	“
7	NODE ID +64	“
8	-	Not used.
9	-	Not used.
10	BAUD RATE	Selects 9600 (off) or Programmed Baud Rate (on)

3.10.6 Jumper Settings

3.10.6.1 Current Input and Output

The Analog inputs can be configured as a current 0(4)-20mA input by placing the jumper on **J7** for AI1 and **J8** for AI2.

The Analog output can be configured as a current 0(4)-20mA output by placing the jumpers **J9**, **J10** and **J11** on the “1” position as shown below.

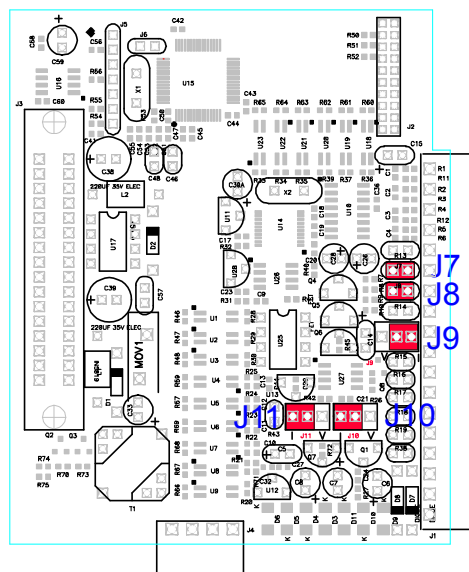

3.10.6.2 Voltage Input and Output

The Analog inputs can be configured as a voltage 0-10V input by removing the jumper from **J7** for AI1 and **J8** for AI2.

The Analog output can be configured as a voltage 0-10V output by placing the jumpers **J9**, **J10** and **J11** on the “V” position as shown below

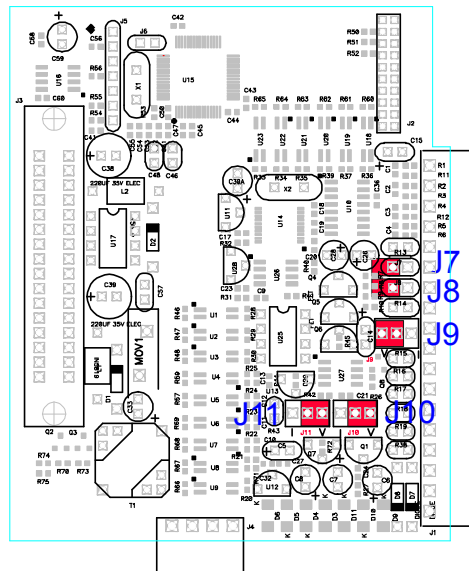

3.10.7 IO-DAIO Data Registers (MODULE TYPE = 112)

Modbus Address	Register Name	Low Limit	High Limit	Access	Comments
10001	Digital Input 1	0	1	R	Status of Digital Inputs.
10002	Digital Input 2	0	1	R	"
10003	Digital Input 3	0	1	R	"
10004	Digital Input 4	0	1	R	"
00017	Digital Output 1	0	1	R/W	Status of Digital Outputs.
00018	Digital Output 2	0	1	R/W	"
30001	S/W Version / Module Type	N/A	N/A	R	High Byte = Software Version Low Byte = 112
30002	Digital Inputs	N/A	N/A	R	Digital Inputs in lower 8 bits. 8 - 1.
40003	Digital Outputs	N/A	N/A	R/W	Digital Outputs in lower 8 bits. 8 - 1.
40004	RTD Input 1	-xxx.x	yyy.y	R	RTD Inputs. See table for range.
40005	RTD Input 2	-xxx.x	yyy.y	R	Resolution in 0.1°C.
40006	Analog Input 1	0	4095	R	Analog Input lower 12 Bits
40007	Analog Input 2	0	4095	R	Analog Input lower 12 Bits
40008	Analog Output 1	0	4095	R/W	Analog Output lower 12 Bits
40009	Counter 1 MSB	0	65535	R/W	Counter MSB and LSB combine to give a 32 bit
40010	Counter 1 LSB	0	65535	R/W	Counter with range 0 to 4294967295.
40011	Counter 2 MSB	0	65535	R/W	"
40012	Counter 2 LSB	0	65535	R/W	"

40013	Counter 3 MSB	0	65535	R/W	"
40014	Counter 3 LSB	0	65535	R/W	"
40015	Counter 4 MSB	0	65535	R/W	"
40016	Counter 4 LSB	0	65535	R/W	"
30100	DIP Switch	0	65535	R	Status of DIP Switch on Front Panel
40101	Watchdog Timer	0	255	R/W	Timer in seconds. 0 = disabled. 1 - 255 = enabled.
40102	Counter Mode	0	2	R/W	0=Disable, 1=Up Counting, 2=Up/Down Count
40103	Input Filter	0	65535	R/W	0 = Disable, >0 = Enable. (x10ms)
40104	RTD 1 Type	1	7	R/W	See RTD Tables.
40105	RTD 2 Type	1	7	R/W	See RTD Tables.
40106	AI 1 Type	1	2	R/W	1 = 0-20mA, 2 = 0-10V
40107	AI 2 Type	1	2	R/W	"
40108	AO Type	1	2	R/W	"
40109	Line Frequency	50	60	R/W	Line Frequency
40110	Units Type	1	2	R/W	1=°C, 2=°F
40121	Baud Rate	2400	11520	R/W	2400, 4800, 9600, 19200, 38400,57600,115200
40122	Parity	0	2	R/W	0 = none, 1 = even, 2 = odd
40123	Stop Bits	1	2	R/W	1 = 1 stop bit, 2 = 2 stop bits
40124	Reply Delay	0	65535	R/W	0 = Disable, >0 = Enable. (x10ms)

3.11 IO-8AOI - ANALOG OUTPUTS

3.11.1 Description

The IO-8AOI is a 8 channel current output module. Each channel can be set to output a current in the range 0 - 20mA. The outputs are isolated from the logic and share a common negative terminal.

The resolution is 12 bits, so writing a value to the Modbus register for each output of 0 - 4095 would give an output current of 0 - 20mA. A value of $819 \pm 1\text{LSB}$ will give a current output of 4mA.

The module configured as slave, where PC/ PLC/ HMI act as Master in the Modbus network. DIP switch 9 should be switched off to make this module as slave. The outputs are written to by the Modbus master device such as a PC/ PLC/ HMI.

3.11.2 Technical Specification of IO-8AOI

Power Supply	Logic Supply Voltage	12 -24 Vdc
	Logic Supply Current	32mA @ 12V / 18mA @ 24V
	Field Supply Voltage	24 Vdc
	Field Supply Current	175mA
Current Output	Output Points	8
	Output Current	0(4) - 20 mA
	Resolution	12 bits
	Drift	100ppm/°C
	Accuracy	0.05% of span
	Compliance	1000 ohms max. @ 24Vdc 500 ohms max. @ 12Vdc
Isolation	Between field and logic	1500Vrms between field and logic
Temperature	Operating Temperature.	-10°C to + 50°C
	Storage Temperature	-40°C to + 85°C
Connectors	Logic Power and Comms.	4 Pin Connector on underside of unit
	Inputs	18 Way screw connector on front

3.11.3 Status Indicators

- Power:** Flashes to indicate the CPU is running.
- RS485 Rx:** Flashes to indicate the unit has received a valid Modbus message.
- RS485 Tx:** Flashes to indicate the unit has sent a Modbus message.
- Output Status:** "ON" when the output is zero
"OFF" when the output is between zero and full scale.
"Flashing" when the output is at full scale

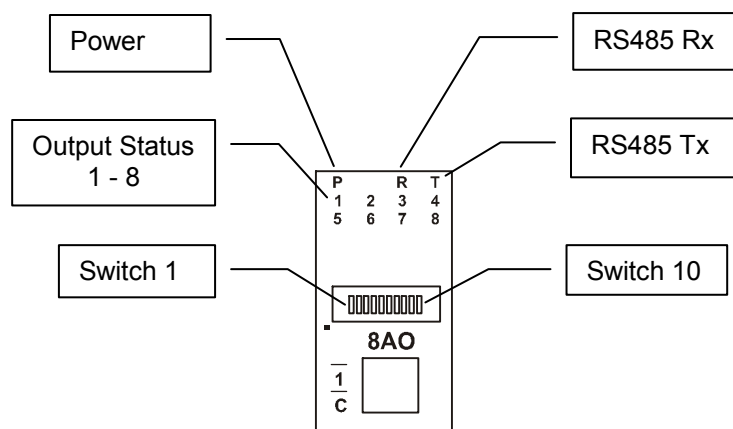

3.11.4 Wiring

The following diagram shows how the analog outputs are connected to a load.

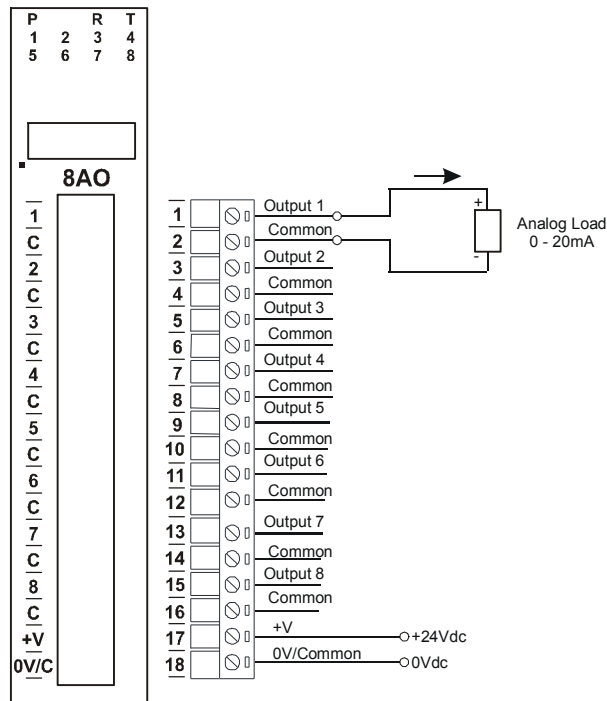

The following diagram shows the wiring for the power and RS485 communications.

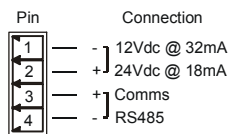

Note: If power/communication connections are reversed, module may become faulty.

3.11.5 Switch Settings

SWITCH	FUNCTION	DESCRIPTION
1	NODE ID +1	Node ID's from 0 to 127 are set up using switches 1 to 7
2	NODE ID +2	"
3	NODE ID +4	"
4	NODE ID +8	"
5	NODE ID +16	"
6	NODE ID +32	"
7	NODE ID +64	"
8	-	Not used.
9	MODE	Slave (Off)
10	BAUD RATE	Selects 9600 (off) or Programmed Baud Rate (on)

3.11.6 IO-8AOI Data Registers (MODULE TYPE = 110)

Modbus Address	Register Name	Low Limit	High Limit	Access	Comments
30001	S/W Version / Module Type	N/A	N/A	R	High Byte = Software Version Low Byte = 110
40002	Current Output 1	0	4095	R/W	Current Outputs. 0 - 4095 = 0(4) - 20mA.
40003	Current Output 2	0	4095	R/W	"
40004	Current Output 3	0	4095	R/W	"
40005	Current Output 4	0	4095	R/W	"
40006	Current Output 5	0	4095	R/W	"
40007	Current Output 6	0	4095	R/W	"
40008	Current Output 7	0	4095	R/W	"
40009	Current Output 8	0	4095	R/W	"
40010	Output Status	0	65535	R	bit2 = 0(0), bit2 = 1(4095) bit1 = 0(OK),bit1 = 1(error)
30100	DIP Switch	0	65535	R	Status of DIP Switch on Front Panel
40101	Watchdog Timer	0	255	R/W	Timer in seconds. 0 = disabled. 1 -255 = enabled.
40121	Baud Rate	2400	11520	R/W	2400,4800,9600,19200,38400,57600,115200
40122	Parity	0	2	R/W	0 = none, 1 = even, 2 = odd
40123	Stop Bits	1	2	R/W	1 = 1 stop bit, 2 = 2 stop bits
40124	Reply Delay	0	65535	R/W	0 = Disable, >0 = Enable. (x10ms)

3.12 IO-8AOV - ANALOG OUTPUTS

3.12.1 Description

The IO-8AOV is a 8 channel voltage output module. Each channel can be set to output a voltage in the range 0 – 10V. The outputs are isolated from the logic and share a common negative terminal.

The resolution is 12 bits, so writing a value to the Modbus register for each output of 0 - 4095 would give an output current of 0 – 10V. A value of $819 \pm 1\text{LSB}$ will give a current output of 2V.

The module configured as slave, where PC/ PLC/ HMI act as Master in the Modbus network. DIP switch 9 should be switched off to make this module as slave. The outputs are written to by the Modbus master device such as a PC/ PLC/ HMI.

3.12.2 Technical Specification of IO-8AOV

Power Supply	Logic Supply Voltage	12 -24 Vdc
	Logic Supply Current	32mA @ 12V / 18mA @ 24V
	Field Supply Voltage	24 Vdc
	Field Supply Current	85 mA max.
Voltage Output	Output Points	8
	Output Voltage	0(2) - 10 V
	Resolution	12 bits
	Drift	100ppm/°C
	Accuracy	0.05% of span
	Compliance	2000 ohms min. load
Isolation	Between field and logic	1500Vrms between field and logic
Temperature	Operating Temperature.	-10°C to + 50°C
	Storage Temperature	-40°C to + 85°C
Connectors	Logic Power and Comms.	4 Pin Connector on underside of unit
	Outputs	18 Way screw connector on front

3.12.3 Status Indicators

- Power:** Flashes to indicate the CPU is running.
- RS485 Rx:** Flashes to indicate the unit has received a valid Modbus message.
- RS485 Tx:** Flashes to indicate the unit has sent a Modbus message.
- Output Status:** "ON" when the output is zero
"OFF" when the output is between zero and full scale.
"Flashing" when the output is at full scale

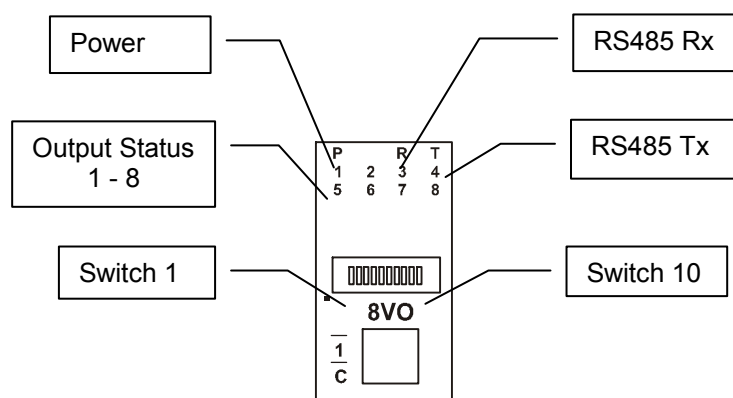

3.12.4 Wiring

The following diagram shows how the analog outputs are connected to a load.

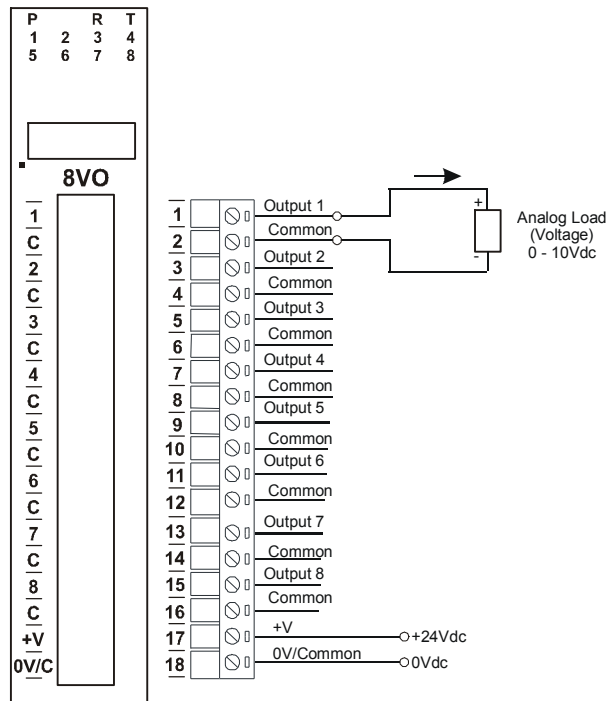

The following diagram shows the wiring for the power and RS485 communications.

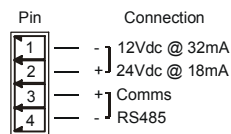

Note: If power/communication connections are reversed, module may become faulty.

3.12.5 Switch Settings

SWITCH	FUNCTION	DESCRIPTION
1	NODE ID +1	Node ID's from 0 to 127 are set up using switches 1 to 7
2	NODE ID +2	"
3	NODE ID +4	"
4	NODE ID +8	"
5	NODE ID +16	"
6	NODE ID +32	"
7	NODE ID +64	"
8	-	Not used.
9	MODE	Off (Slave)
10	BAUD RATE	Selects 9600 (off) or Programmed Baud Rate (on)

3.12.6 IO-8AOV Data Registers (MODULE TYPE = 111)

Modbus Address	Register Name	Low Limit	High Limit	Access	Comments
30001	S/W Version / Module Type	N/A	N/A	R	High Byte = Software Version Low Byte = 111
40002	Voltage Output 1	0	4095	R/W	Voltage Outputs. 0 - 4095 = 0 - 10V.
40003	Voltage Output 2	0	4095	R/W	"
40004	Voltage Output 3	0	4095	R/W	"
40005	Voltage Output 4	0	4095	R/W	"
40006	Voltage Output 5	0	4095	R/W	"
40007	Voltage Output 6	0	4095	R/W	"
40008	Voltage Output 7	0	4095	R/W	"
40009	Voltage Output 8	0	4095	R/W	"
40010	Output Status	0	65535	R	bit2 = 0(0), bit2 = 1(4095) bit1 = 0(OK),bit1 = 1(error)
30100	DIP Switch	0	65535	R	Status of DIP Switch on Front Panel
40101	Watchdog Timer	0	255	R/W	Timer in seconds. 0 = disabled. 1 -255 = enabled.
40121	Baud Rate	2400	11520	R/W	2400,4800,9600,19200,38400,57600,115200
40122	Parity	0	2	R/W	0 = none, 1 = even, 2 = odd
40123	Stop Bits	1	2	R/W	1 = 1 stop bit, 2 = 2 stop bits
40124	Reply Delay	0	65535	R/W	0 = Disable, >0 = Enable. (x10ms)

4. IO STUDIO

This is PC software used for setting communication parameters of the IO module, Read IO status directly in PC, Force Outputs to test the module and used as tool for module diagnostic purpose.



Install IO Studio software in PC.

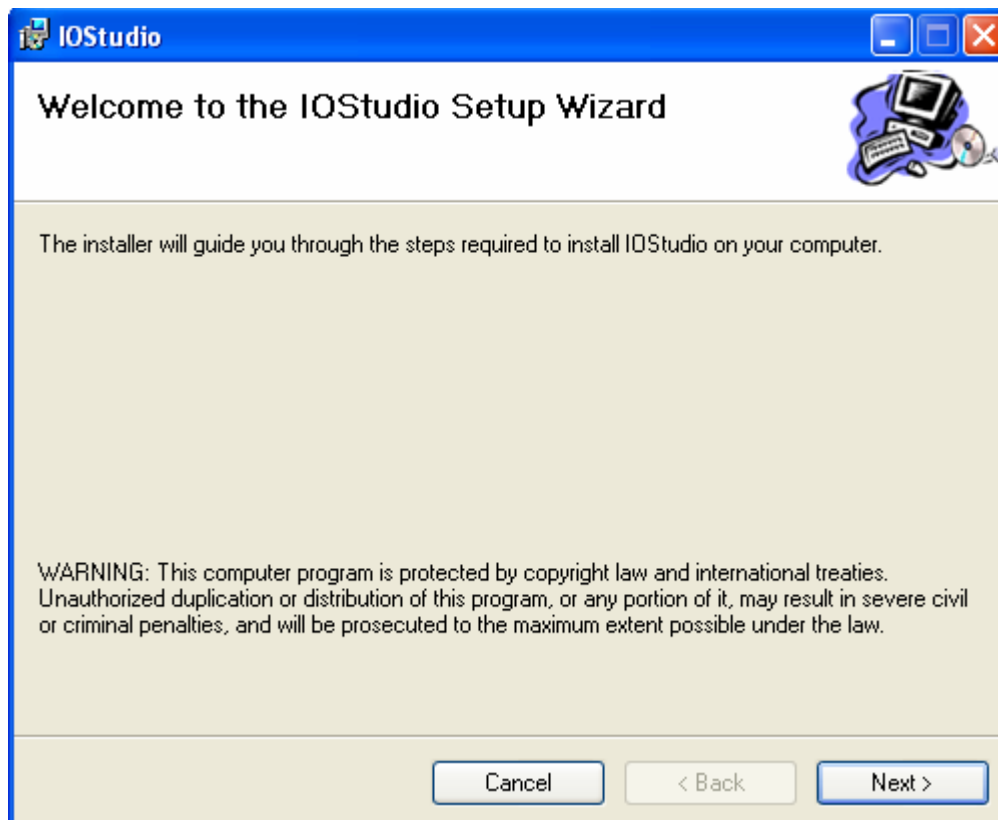

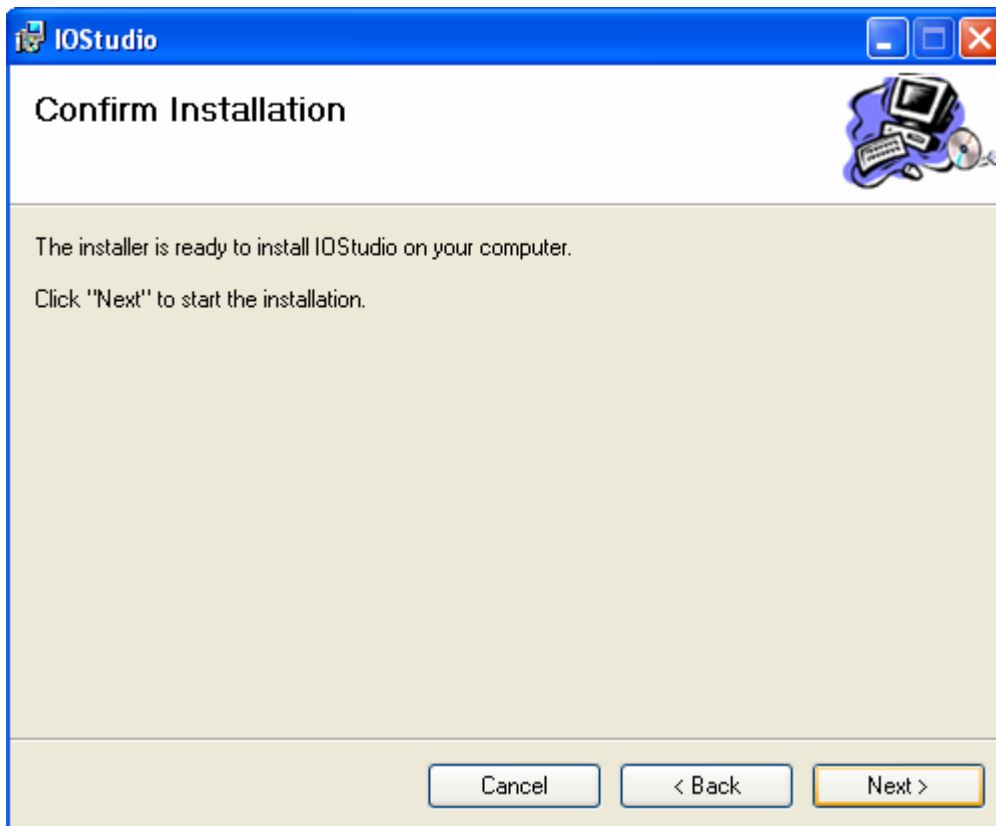
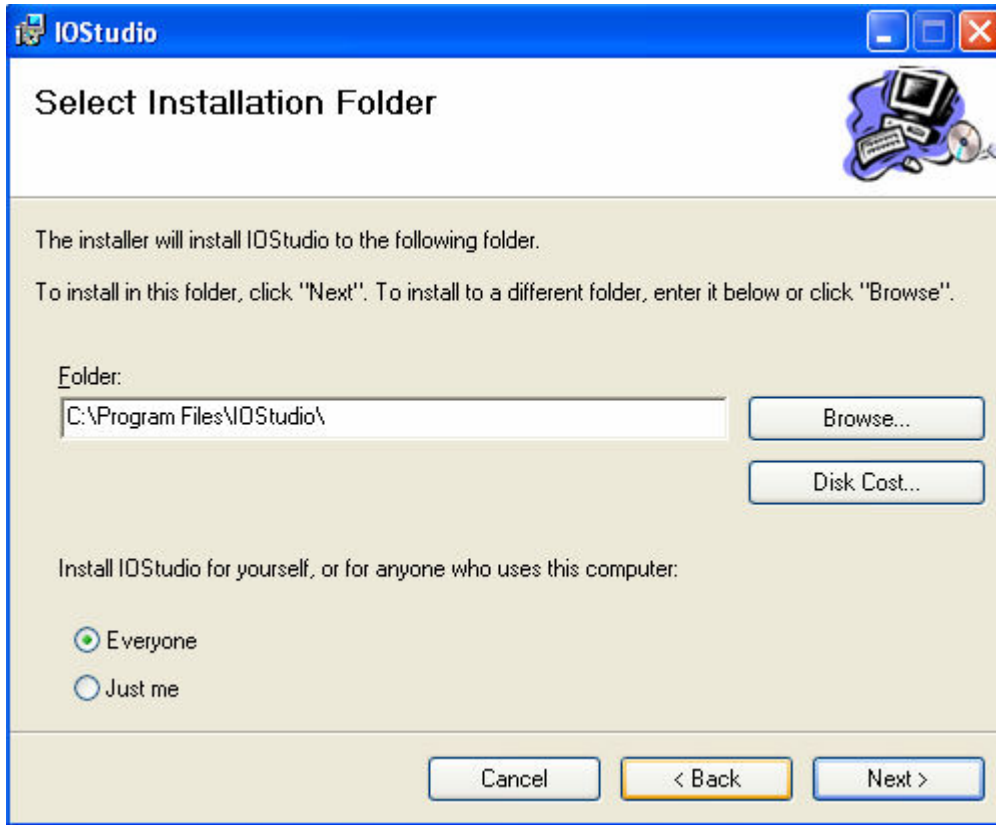

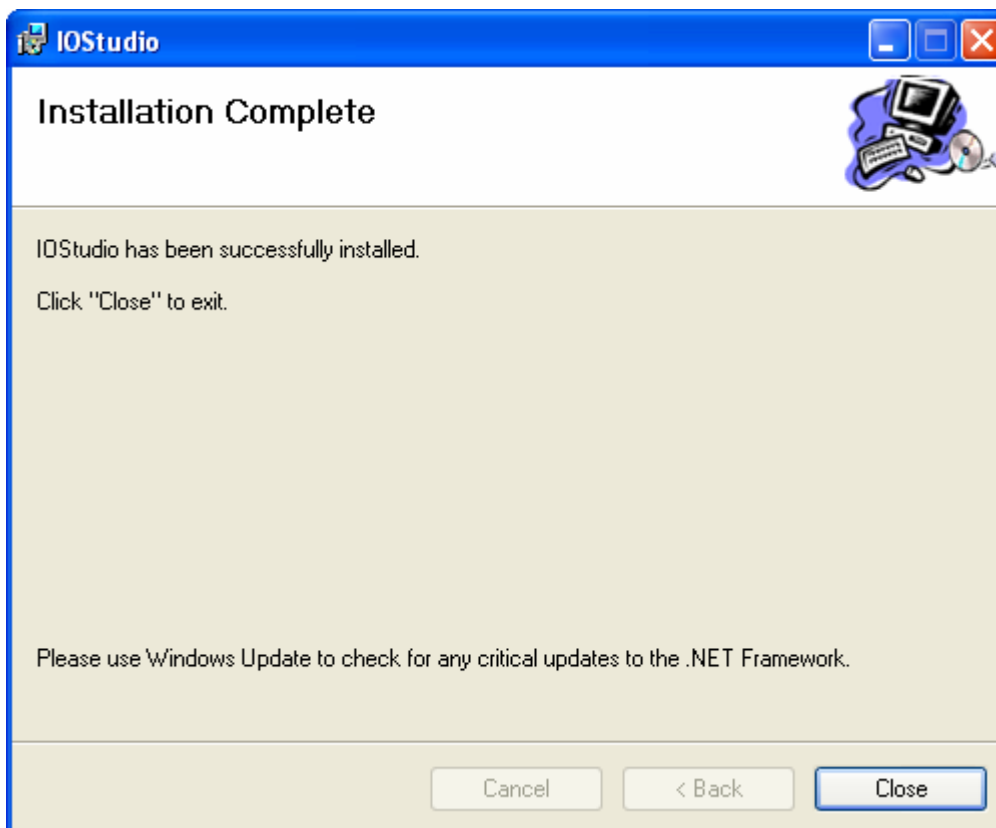
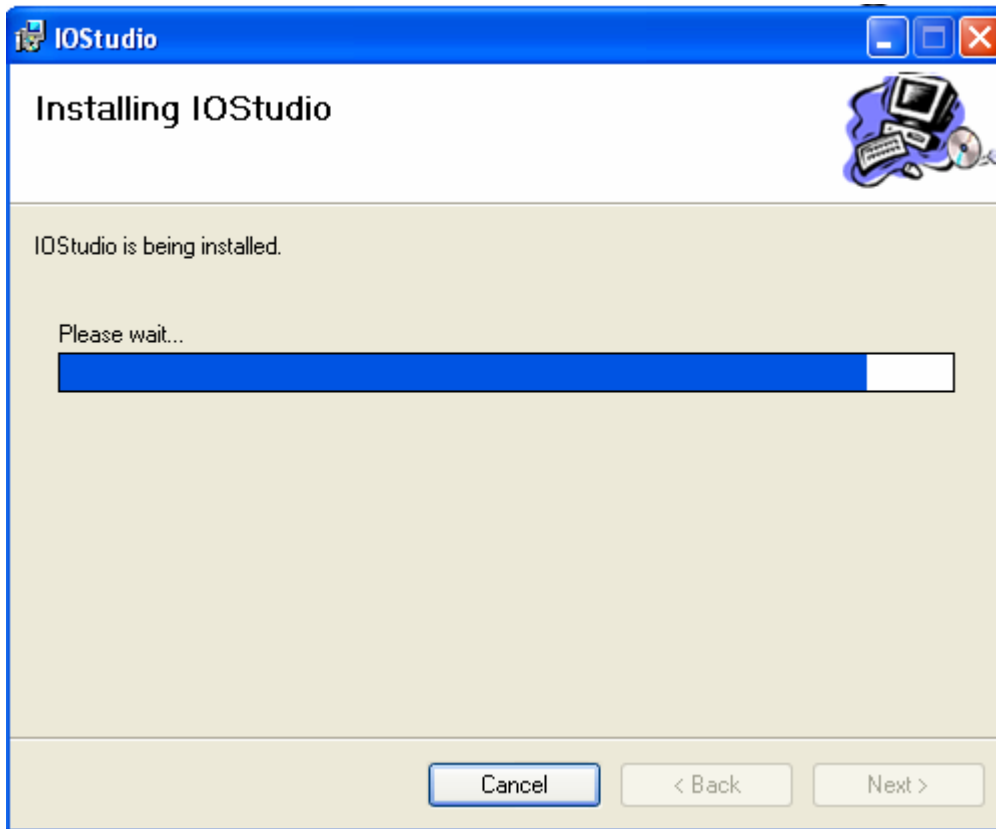

IO Module: Set address say 1 for the IO Module using DIP switches on the Module itself. Connect 24V DC Power supply and make sure that Dip switch10 is Off to allow communication of IO Module with other devices on Default communication settings. If you are using RS232/RS485 converter like SNA10A from Brainchild make sure that you have selected all the communication settings properly as follows.

BAUD RATE	9600
DATA BITS	8
PARITY	NONE
STOP BITS	1

In the PC, select above settings at the COM port.
Right click on Mycomputer –Properties - Hardware-Device Manager- COM ports

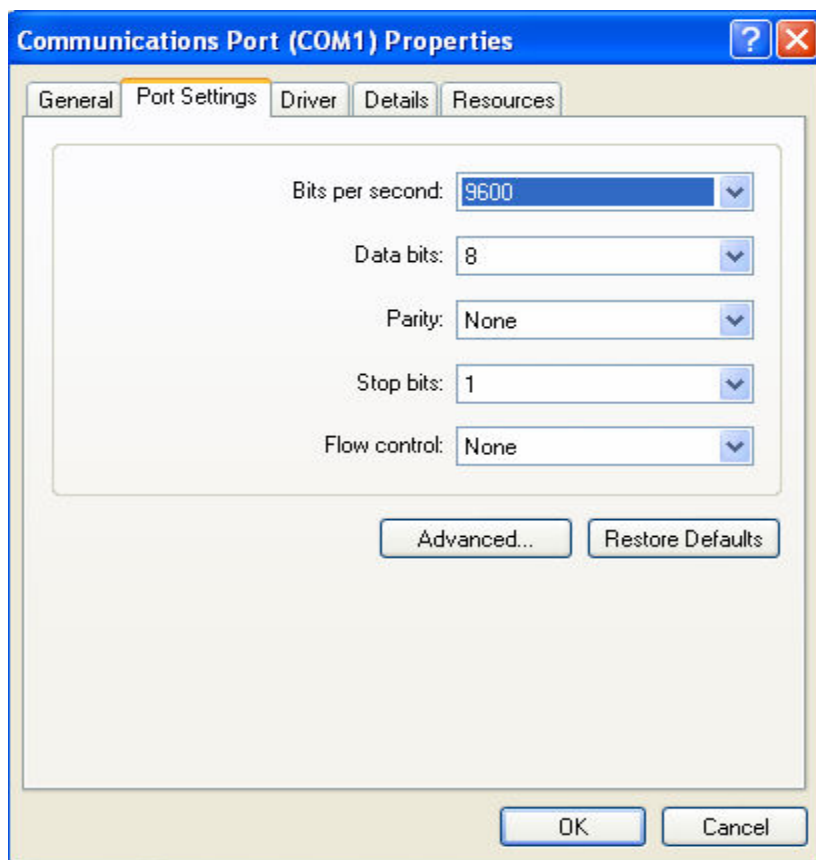

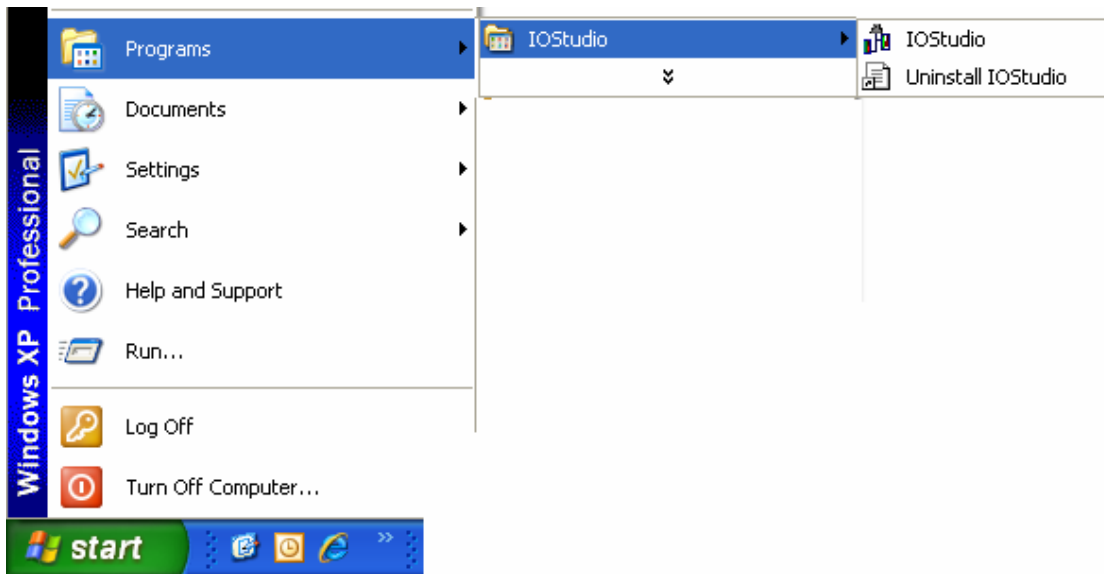

Start the IO Studio software as shown above.

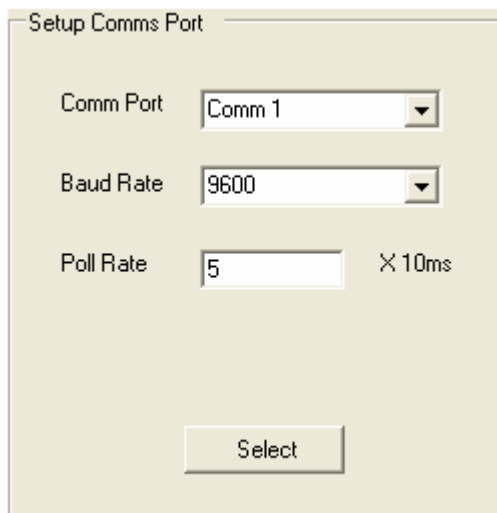
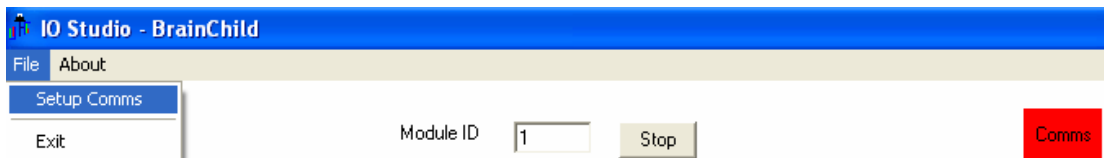

If every thing is proper, IO Studio will read the IO Module and show the status of the IO registers. If it shows RED indication as above, then please check the dip switch status on the IO Module, RS232/RS485 converter settings and COM settings in the PC and also check the cable that is used between PC and RS232/RS485 converter. Many times, you might have more than one COM port on your PC, You should make sure that which COM port is using for this purpose and select the correct COM port in the above shown setup.

IO-16DI

Module Type: 100
 Software Version: 1

Modbus Address	Value	Label
10001	0	Digital Input 1
10002	0	Digital Input 2
10003	0	Digital Input 3
10004	0	Digital Input 4
10005	0	Digital Input 5
10006	0	Digital Input 6
10007	0	Digital Input 7
10008	0	Digital Input 8
10009	0	Digital Input 9
10010	0	Digital Input10
10011	0	Digital Input11
10012	0	Digital Input12
10013	0	Digital Input13
10014	0	Digital Input14
10015	0	Digital Input15
10016	0	Digital Input16
30001	356	Type/SW Version
30002	0	Input Status
40003	0	Counter 1
40005	0	Counter 2

Description of Modbus Register

Status of Digital Input 1.

Red (0) = OFF
 Green (1) = ON

Move Mouse pointer over Value for Description

IO-16DO

Module Type: 101
 Software Version: 1

Modbus Address	Value	Label
1	1	Digital Output 1
2	1	Digital Output 2
3	1	Digital Output 3
4	1	Digital Output 4
5	1	Digital Output 5
6	1	Digital Output 6
7	1	Digital Output 7
8	1	Digital Output 8
9	0	Digital Output 9
10	0	Digital Output10
11	0	Digital Output11
12	0	Digital Output12
13	0	Digital Output13
14	0	Digital Output14
15	0	Digital Output15
16	0	Digital Output16
30001	357	Type/SW Version
40002	255	Output Status
30100	1	DIP Switch
40101	0	Output Watchdog Timer

Description of Modbus Register

Status of Digital Output 8.

Red (0) = OFF
 Green (1) = ON

Double Click to change

Move Mouse pointer over Value for Description

IO-4RO

Module Type: 113
 Software Version: 1

Modbus Address	Value	Label
1	1	Relay Output 1
2	1	Relay Output 2
3	0	Relay Output 3
4	0	Relay Output 4
30001	369	Type/SW Version
40002	3	Output Status
30100	1	DIP Switch
40101	0	Output Watchdog Timer
40102	0	Modbus Master Timeout
40103	0	Modbus Master Rate
40121	1	Baud Rate
40122	0	Parity
40123	0	Stop Bit
40124	0	Reply Delay

Description of Modbus Register

Status of Relay Output 2.

Red (0) = OFF
 Green (1) = ON

Double Click to change

Move Mouse pointer over Value for Description

IO-8DIO

Module Type: 102
 Software Version: 1

Modbus Address	Value	Label
10001	0	Digital Input 1
10002	0	Digital Input 2
10003	0	Digital Input 3
10004	0	Digital Input 4
10005	0	Digital Input 5
10006	0	Digital Input 6
10007	0	Digital Input 7
10008	0	Digital Input 8
17	1	Digital Output 1
18	1	Digital Output 2
19	1	Digital Output 3
20	1	Digital Output 4
21	0	Digital Output 5
22	0	Digital Output 6
23	0	Digital Output 7
24	0	Digital Output 8
30001	358	Type/SW Version
30002	0	Input Status
40003	15	Output Status
40004	0	Counter 1

Description of Modbus Register

Status of Digital Output 4.

Red (0) = OFF
 Green (1) = ON

Double Click to change

Move Mouse pointer over Value for Description

IO-8AI

Module Type: 103
 Software Version: 1

Modbus Address	Value	Label
30001	359	Type/SW Version
30002	0	Current Input 1
30003	0	Current Input 2
30004	0	Current Input 3
30005	0	Current Input 4
30006	0	Current Input 5
30007	0	Current Input 6
30008	0	Current Input 7
30009	0	Current Input 8
30010	21845	Input Status
30100	1	DIP Switch
40121	1	Baud Rate
40122	0	Parity
40123	0	Stop Bit
40124	0	Reply Delay

Description of Modbus Register

0 - 20mA Current Input 1
 Range = 0 - 4095 (12 bits)

Move Mouse pointer over Value
 for Description

IO-8AIV

Module Type: 104
 Software Version: 1

Modbus Address	Value	Label
30001	360	Type/SW Version
30002	0	Analog Input 1
30003	0	Analog Input 2
30004	0	Analog Input 3
30005	0	Analog Input 4
30006	0	Analog Input 5
30007	0	Analog Input 6
30008	0	Analog Input 7
30009	0	Analog Input 8
30010	21845	Input Status
30100	1	DIP Switch
40121	1	Baud Rate
40122	0	Parity
40123	0	Stop Bit
40124	0	Reply Delay

Description of Modbus Register

0 - 10V Voltage Input 1
 Range = 0 - 4095 (12 bits)

Move Mouse pointer over Value
 for Description

IO-8TC

Module Type: 105
 Software Version: 1

Modbus Address	Value	Label
30001	361	Type/SW Version
30002	166	Thermocouple Input 1
30003	-32768	Thermocouple Input 2
30004	-32768	Thermocouple Input 3
30005	-32768	Thermocouple Input 4
30006	-32768	Thermocouple Input 5
30007	-32768	Thermocouple Input 6
30008	-32768	Thermocouple Input 7
30009	-32768	Thermocouple Input 8
30010	215	CJC Temperature
30011	21844	Input Status
30016	65415	Calibrate Raw Data
40017	0	Calibrate Control
30100	1	DIP Switch
40101	1	Thermocouple Type
40102	50	Line Frequency
40103	100	CJC Offset
40104	1	Display Units °C/°F
40121	1	Baud Rate
40122	0	Parity

Description of Modbus Register

Thermocouple Input 1

Range = -xxx.x to +yyyy.y

Example: 101.4°C will be read back as 1014

Move Mouse pointer over Value for Description

IO-6RTD

Module Type: 109
 Software Version: 1

Modbus Address	Value	Label
30001	365	Type/SW Version
30002	8500	RTD Input 1
30003	-32768	RTD Input 2
30004	-32768	RTD Input 3
30005	-32768	RTD Input 4
30006	-32768	RTD Input 5
30007	-32768	RTD Input 6
30008	1364	Input Status
30016	34423	Calibrate Raw Data
40017	0	Calibrate Control
30100	1	DIP Switch
40101	1	RTD Type
40102	50	Line Frequency
40103	0	Display Units °C/°F
40121	1	Baud Rate
40122	0	Parity
40123	0	Stop Bit
40124	0	Reply Delay

Description of Modbus Register

RTD Input 1

Range = -xxx.x to +yyyy.y

Example: 101.4°C will be read back as 1014

Move Mouse pointer over Value for Description

IO-DA10

Module Type: 112
Software Version: 1

Modbus Address	Value	Label
10001	0	Digital Input 1
10002	0	Digital Input 2
10003	0	Digital Input 3
10004	0	Digital Input 4
17	1	Digital Output 1
18	0	Digital Output 2
30001	368	Type/SW Version
30002	0	Input Status
40003	1	Output Status
30004	-32768	RTD Input 1
30005	-32768	RTD Input 2
30006	0	Analog Input 1
30007	0	Analog Input 2
40008	0	Analog Output 1
40009	0	Counter 1
40011	0	Counter 2
40013	0	Counter 3
40015	0	Counter 4
30091	0	Calibrate Raw Data
40092	0	Calibrate Channel

Description of Modbus Register

Status of Digital Output 1.

Red (0) = OFF
Green (1) = ON

Double Click to change

Move Mouse pointer over Value for Description

IO Studio - BrainChild
File About

Module ID

IO-16DI

Module Type: 100
Software Version: 1

Modbus Address	Value	Label
40044	0	Counter Capture 5
40046	0	Counter Capture 6
40048	0	Counter Capture 7
40050	0	Counter Capture 8
40052	0	Counter Capture 9
40054	0	Counter Capture 10
40056	0	Counter Capture 11
40058	0	Counter Capture 12
40060	0	Counter Capture 13
40062	0	Counter Capture 14
40064	0	Counter Capture 15
40066	0	Counter Capture 16
30100	1	DIP Switch
40101	1	Counter Mode
40102	0	Input Filter
40103	0	Counter Zero
40121	1	Baud Rate
40122	0	Parity
40123	0	Stop Bit
40124	0	Reply Delay

Description of Modbus Register

Baud Rate - Enter one of the following values, then switch on SW10 to enable

2400
4800
9600
19200
38400
57600
11520

Move Mouse pointer over Value for Description

Configuration:

For ex: If you want set baud rate, enter the required value in the register 40121, then press enter in the PC keyboard. Set all the parameters once and then switch off the power supply to the IO Module. Now switch on the Dip switch 10 on the module to make above settings effective. After power on, the IO Module will have new Communication settings. Please note that at this point of time, IO module may not communicate with PC because you may have different settings at RS232/RS485 converter and also COM port settings in the PC.

Testing the IO Module:

For ex: If you want to test IO-16DO module. It contains total 16 digital outputs. You can connect IO module with PC as explained above via RS232/RS485 converter. You can force digital output from low to high and check its status at the IO module and also u can observe LED status on the IO Module itself.

5. SPECIFICATIONS

5.1 ENVIRONMENTAL

Operating Temperature	-10°C to +50°C
Storage Temperature	-40°C to +85°C
Humidity	Up to 95% non condensing

5.2 EMC INSTALLATION INSTRUCTIONS

1. Screened twisted pair RS485 cable must be used with the screen grounded at one point only.
2. The RS485 cable must be terminated at both ends using a 120ohm resistor.
3. Use should be made of screened I/O, T/C, RTD cable with the screens grounded at one point as close to the IO module as possible.

5.3 CONFORMITY CERTIFICATE

DECLARATION OF CONFORMITY
according to EN 45014

Manufacturer's Name: Brainchild Electronic. Co. Ltd.,

Manufacturer's Address: No. 209, Chung Yong Road
Nan Kang District
Taipei, Taiwan, R.O.C

declares that the following IO products

Model Number(s): IO-16DI, IO-16DO, IO-DIO, IO-4RO, IO-8AII, IO-8AIV,
IO-8AIIS, IO-8AIVS, IO-8AO, IO-8VO, IO-8TC,
IO-8TCS, IO-6RTD, IO-DAIO

complies with EMC Directive 89/336/EEC and Low Voltage Equipment Directive 73/23/EEC and conforms to the following Product specifications:

Safety: IEC 950

EMC: IEC 61000-4-2-A1 Level 2

IEC 61000-4-3-A1 Level 2

IEC 61000-4-4 Level 3

CISPR 11:1997-A1 / EN 55011:1998 Group 1 Class A

TAIPEI, TAIWAN
Location

April 2007
Date

Mr. Peter Lio
Vice President

5.4 EMC Test Results

EMC Test Results									
Test	Standard	Test Value	Product Compliance (IO)						
Immunity Test Results EN 61326-1			16DI	16DO	4RO	8DIO	8AII	8AIIS	8AIV
Electrostatic Discharge	IEC 61000-4-2	8KV Air	A	A	A	A	A	B	A
		4KV Contact	A	A	A	A	A	A	A
Radiated Field	IEC 61000-4-3	10V/m	A	A	A	A	A	A	A
Fast Transients	IEC 61000-4-4	Power 2KV	A	A	A	A	A	B	A
		I/O 1KV	A	A	A	A	A	B	A
Surge	IEC 61000-4-5	Power 1KV/2KV	A	A	A	A	A	A	A
RF Conducted	IEC 61000-4-6	Power 3 Vrms	A	A	A	A	A	A	A
Voltage Interrupt	IEC 61000-4-11	0.5cycle 100%	A	A	A	A	A	A	A
Emissions Test Results EN 61326-1 Class A									
Radiated Emissions	CISPR 22	Class A	✓	✓	✓	✓	✓	✓	✓
Conducted Emissions	CISPR 22	Class B	✓	✓	✓	✓	✓	✓	✓

Test	Standard	Test Value	Product Compliance (IO)						
Immunity Test Results EN 61326-1			8AIVS	8TC	8TCS	6RTD	DAIO	8AOI	8AOV
Electrostatic Discharge	IEC 61000-4-2	8KV Air	B	A	B	A	A	A	B
		4KV Contact	A	A	A	A	A	A	A
Radiated Field	IEC 61000-4-3	10V/m	A	A	A	A	A	A	A
Fast Transients	IEC 61000-4-4	Power 2KV	B	A	B	A	A	A	A
		I/O 1KV	B	A	B	A	A	A	A
Surge	IEC 61000-4-5	Power 1KV/2KV	A	A	A	A	A	A	A
RF Conducted	IEC 61000-4-6	Power 3 Vrms	A	A	A	A	A	A	A
Voltage Interrupt	IEC 61000-4-11	0.5cycle 100%	A	A	A	A	A	A	A
Emissions Test Results EN 61326-1 Class A									
Radiated Emissions	CISPR 22	Class A	✓	✓	✓	✓	✓	✓	✓
Conducted Emissions	CISPR 22	Class B	✓	✓	✓	✓	✓	✓	✓